

# Effectiveness of Multiple Tuned Mass Dampers

S. S. Patil, S.B.Javheri, C.G.Konapure

**Abstract**—The seismic waves caused by an earthquake sway structures like E.S.R tanks, bridges, buildings in various ways depending on the frequency & direction of ground motion, and the height of the structure. In order to reduce the sway of structure, it is important to place large dampers into their design to interrupt the frequency. Various parameters like mass ratio, damping ratio and stiffness of structure are considered. The objective of research paper is to prove that, the use multiple tuned mass dampers(MTMD) rather than single tuned mass damper(STMD) can reduce the sway of structure within limit. For this a case study of R.C.C. ESR having capacity of 40m<sup>3</sup> is considered.

**Index Terms**—Tuned Mass Damper, Dampin Ratio, Stiffness, Mass Ratio, Multiple Tuned Mass Damper, Single Tuned Mass Damper.

## I. INTRODUCTION

The seismic waves caused by an earthquake make structure to sway and oscillate in various ways depending on the frequency and direction of ground motion and height of structure. In order to enhance the structural seismic performance, a proper structure design is formulated engaging various seismic vibration control technologies. Tuned mass damper is a classical device consisting of an absorber mass, spring and viscous damper attached to main system. Today TMD's are extensively used in civil engineering structures to suppress vibrations due to wind and earthquake forces. A case study of ESR water tank having capacity 40 m<sup>3</sup> is considered for the comparative study of multiple tuned mass damper (MTMD) and single tuned mass damper (STMD).

## II. TUNED MASS DAMPER (TMD)

A TMD consists of a mass mounted on a structure via a spring system and a viscous damper, preferably in a location where the structure's deflections are greatest. The spring and mass are 'tuned' so as to have a natural frequency close to that of the primary structure. When properly tuned, the TMD mass oscillates in the opposite direction from the primary structure. The motion of the mass relative to the main structure can be very large when the system is properly tuned and this provides an opportunity to dissipate a substantial amount of energy in the damper linking the mass to the main structure. The optimum configuration of the spring system will vary depending on the application. The TMD principle also applies to individual components prone to vibration such as slender columns, truss members and struts. The multiple tuned dampers mass have been proposed about a decade ago as a better option for single TMD. The basic configuration of MTMD structure system comprises a number of TMDs attached to the main structure as shown in the figure 1 .

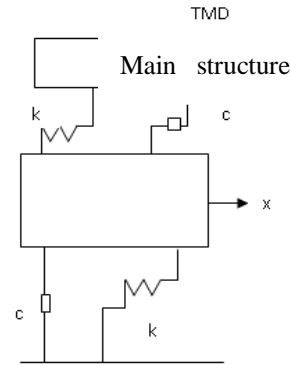

Fig 1 Idealized Structural model of TMD

## III. THEROTICAL FORMULATION

### (A) Structure with Single Tuned Mass Damper

For structure attached with STMD (Single tuned mass damper). Consider a structure attached with single tuned mass damper. Let,  $m_s$ ,  $k_s$ ,  $c_s$ , and  $R_s$  are the properties of main structure. Similarly,  $m_1$ ,  $\omega_1$ ,  $R_1$ ,  $c_1$ , are the properties of single tuned mass damper attached to the structure.

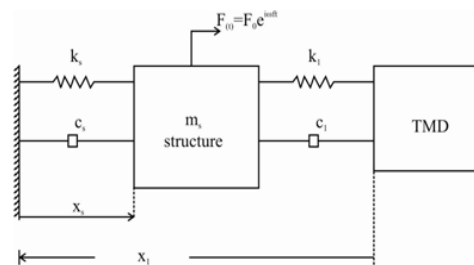

Fig 2 Idealized Structural model for STMD.

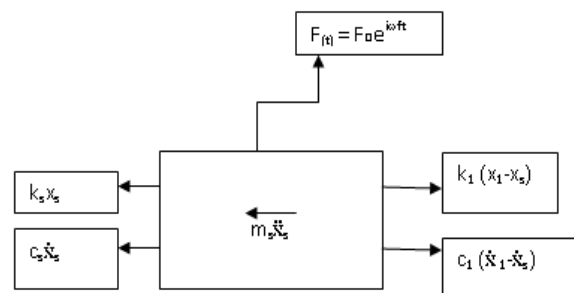

Fig 3 Mathematical model of structure with STMD

$$m_s \ddot{x}_s + c_s \dot{x}_s + k_s x_s - c_1 (\dot{x}_1 - \dot{x}_s) - k_1 (x_1 - x_s) = F(t) \quad - (1)$$

$$\therefore m_s \ddot{x}_s + \dot{x}_s (c_1 + c_s) + (k_s + k_1) x_s - c_1 \dot{x}_1 - k_1 x_1 = F_{(t)}$$

(B) Structure with Multiple Tuned Mass Damper

$$F_0 e^{i\omega_f t}$$

$$x_s = X_s e^{i\omega_f t}$$

$$\dot{x}_s = X_s i \omega_f e^{i\omega_f t}$$

$$\ddot{x}_s = X_s i^2 \omega_f^2 e^{i\omega_f t} = -X_s \omega_f^2 e^{i\omega_f t}$$

$$\text{for } x_1 = X_1 e^{i\omega_f t}$$

$$\dot{x}_1 = \omega_f i e^{i\omega_f t} X_1$$

$$\ddot{x}_1 = -\omega_f^2 X_1 e^{i\omega_f t}$$

$$c = R_s c_s$$

$$c = R_s (2m_s \omega_f)$$

$$c_s = R_s m_s \omega_f$$

$$c_1 = 2R_1 m_1 \omega_1$$

$$\omega = \sqrt{k/m}$$

$$\frac{m_1}{m_s} = \mu_1; \frac{\omega_f}{\omega_s} = a; \frac{\omega_1}{\omega_s} = r_1$$

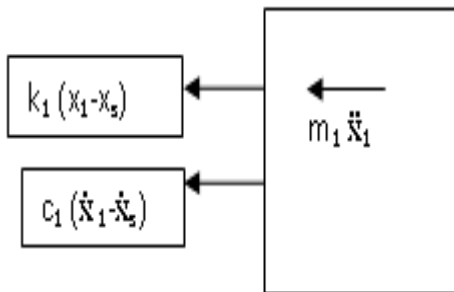

Fig 4 Mathematical Model for STMD

$$\therefore x_s = \frac{[F_0 / m_s \omega_s^2]}{[\text{Re}(x) + i\text{Im}(z)]}$$

$$\text{Re}(z) = 1 - \frac{\omega_f^2}{\omega_s^2} - [\mu_k a^2] [r_k^2 (r_k^2 - a^2) + (2R_k r_k a)^2] / [(r_k^2 - a^2)^2 + (2R_k r_k a)^2]$$

$$i\text{Im}(z) = 2 R_s R \frac{\omega_f}{\omega_s} + (2\mu_k r_k R_k a^5) / [(r_k^2 - a^2)^2 + (2R_k r_k a)^2]$$

$$(2R_k r_k a)^2]$$

Where,  $\text{Re}(z)$  and  $i\text{Im}(z)$  are real and imaginary number respectively.

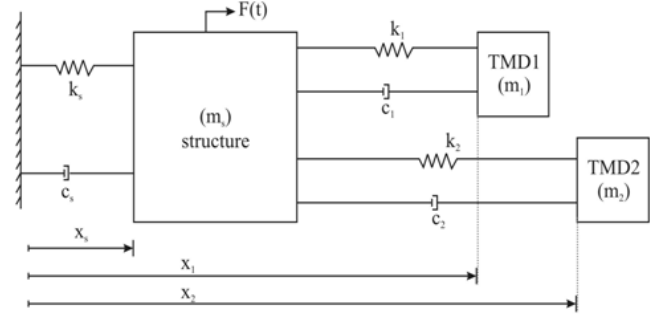

Fig 5 Idealized Structural model for MTMD

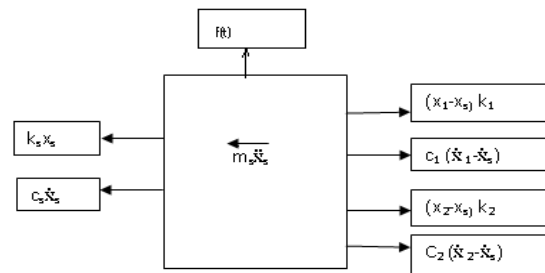

Fig 6 mathematical model for structure with MTMD

$$\therefore m_s \ddot{x}_s + c_s \dot{x}_s + k_s x_s - (x_1 - x_s) k_1 - (\dot{x}_1 - \dot{x}_s) c_1 - (x_2 - x_s) k_2 - (\dot{x}_2 - \dot{x}_s) c_2 = F_{(t)}$$

$$x_s = X_s e^{i\omega_f t}$$

$$\dot{x}_s = X_s i \omega_f e^{i\omega_f t}$$

$$\ddot{x}_s = X_s i^2 \omega_f^2 e^{i\omega_f t} = -X_s \omega_f^2 e^{i\omega_f t}$$

$$c = R_s c_s$$

$$c = R_s (2m_s \omega_f)$$

$$c_s = R_s m_s \omega_f$$

$$c_1 = 2R_1 m_1 \omega_1$$

$$\omega = \sqrt{k/m}$$

$$\frac{m_1}{m_s} = \mu_1; \frac{\omega_f}{\omega_s} = a; \frac{\omega_1}{\omega_s} = r_1, \frac{\omega_2}{\omega_s} = r_2$$

We have,

$$\therefore x_1 = \frac{[r_1^4 - r_1^2 a^2 + 4R_{11}^2 r_1^2 a^2 - 2iR_{11} r_1 a^3]}{[(r_1^2 - a^2)^2 + (2R_{11} r_1 a)^2]}$$

$$x_2 = \frac{[r_2^4 - r_2^2 a^2 + 4R_{12}^2 r_2^2 a^2 - 2iR_{12} r_2 a^3]}{[(r_2^2 - a^2)^2 + (2R_{12} r_2 a)^2]} x_s$$

Where,

$$\operatorname{Re}(z) =$$

$$1 - \left[ \frac{\omega_f}{\omega_s} \right]^2 - \sum_{k=1}^n \frac{[m_k a^2 [r_k^2 (r_k^2 - a^2)] + (2 R_{1k} r_k a)^2]}{[(r_k^2 - a^2)] + (2 R_{1k} r_k a)^2}$$

$$\operatorname{Im}(z) =$$

$$(2 R_s) \left( \frac{\omega_f}{\omega_s} \right) + \sum_{k=1}^n \frac{[2 m_k r_k R_{1k} a^5]}{[(r_k^2 - a^2)^2 + (2 R_{1k} r_k a)^2]}$$

$$\text{Lateral force} = W \times (\alpha h) = 97063 \times 0.03375$$

$$= 3276 \text{ kg}$$

Using concept  $F = k \delta$

$$k = F / \delta$$

$$= 32760 / 0.37$$

$$= 88301.886 \text{ N/m}$$

So the required information is

Mass of structure = 97063 kg

Stiffness of structure = 88301.886 N/m.

#### IV. COMPARATIVE STUDY OF STMD & MTMD

##### A. R.C.C ESR water tank having following data.

- 1) Capacity: -40m<sup>3</sup>
- 2) L.D.L:-12.0
- 3) Free board :-0.3m
- 4) S.B.C of soil:-25 MT/ m<sup>3</sup>
- 5) Seismic zone: IV

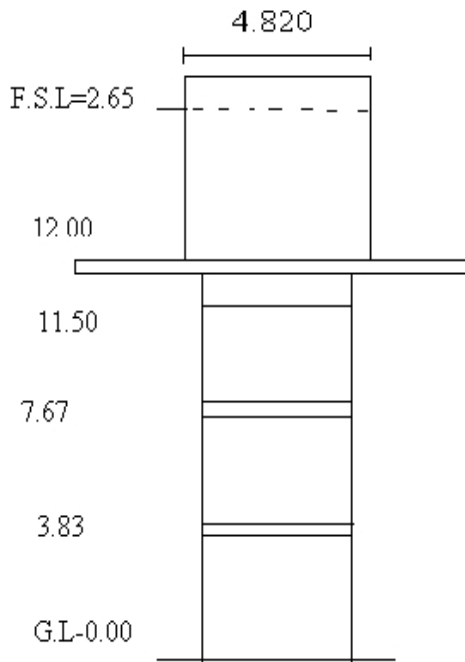

Fig 7 . Water Tank (ESR) Elevation

Using I. S. 1893-2000

Consider  $R_s$ = Damping of structure

$$= 5\% = 0.05$$

Lateral displacement at top  $\delta = 0.370 \text{ m}$

$$\text{Period } T = 2\pi \times \sqrt{(0.37/9.81)} = 1.2 \text{ sec}$$

Ref I.S.1893,

Fig No 5 with 5% critical damping

$$S_a/g = 0.09$$

$$\alpha h = 1.0 \times 1.5 \times 0.25 \times 0.09 = 0.03375$$

**B Using ESR structure attached with STMD and MTMD following results are obtained.**

Table 4.2 (I) For  $R_d=0.05$

Mass Ratio	Displacement in (mm)	
	STMD	MTMD
0.1	93.8	72.59
0.15	81.8	92.1
0.2	72.59	49.99
0.25	65.22	43.25
0.3	59.21	38.124

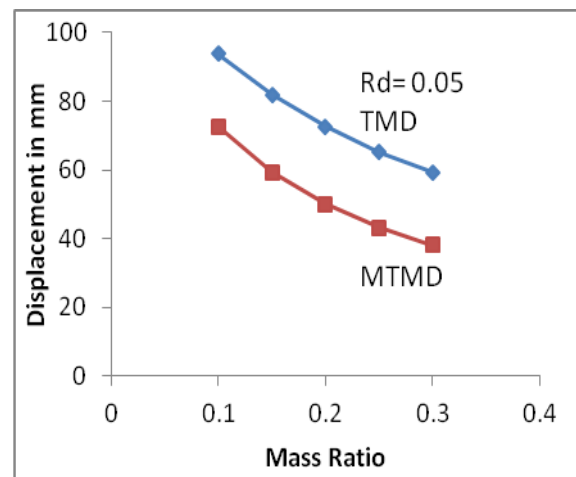

Graph 1 for  $R_d=0.05$   
Table 4.2 (II) For  $R_d=0.06$

Mass Ratio	Displacement in (mm)	
	STMD	MTMD
0.1	90.6	68.9
0.15	78.31	55.5
0.2	68.9	46.56
0.25	61.53	40.07
0.3	55.5	35.16

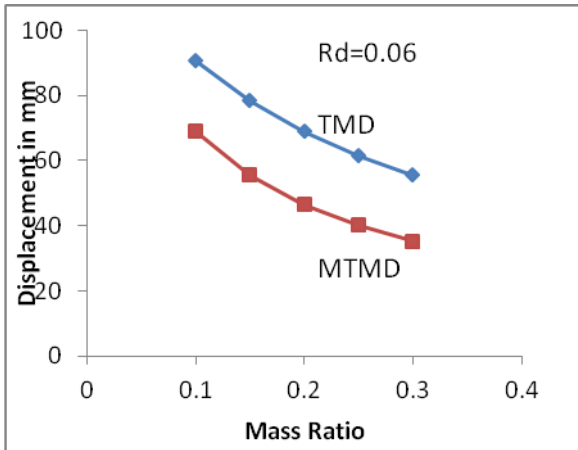

Graph 2 for Rd=0.06  
Table 4.2 (III) for Rd=0.07

Mass Ratio	Displacement in (mm)	
	TMD	MTMD
0.1	87.42	65.22
0.15	74.7	52.02
0.2	65.22	43.26
0.25	57.88	37.028
0.3	52.022	32.36

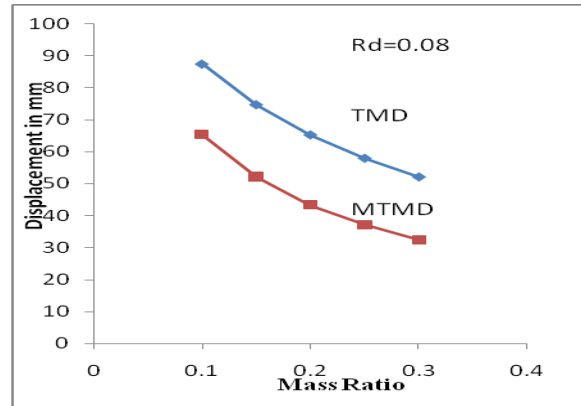

Graph 4 for Rd = 0.08  
Table 4.2 (V) for Rd=0.09

Mass Ratio	Displacement in (mm)	
	TMD	MTMD
0.1	86.85	64.6
0.15	74.096	51.427
0.2	64.03	42.715
0.25	57.26	36.52
0.3	51.42	31.905

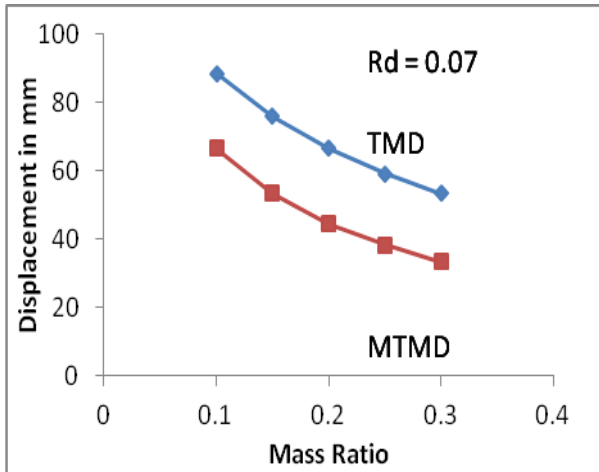

Graph 3 for Rd = 0.07  
Table 4.2 (IV) for Rd=0.08

Mass Ratio	Displacement in (mm)	
	STMD	MTMD
0.1	88.6	66.58
0.15	76.03	53.31
0.2	66.58	44.46
0.25	59.21	38.129
0.3	53.33	33.37

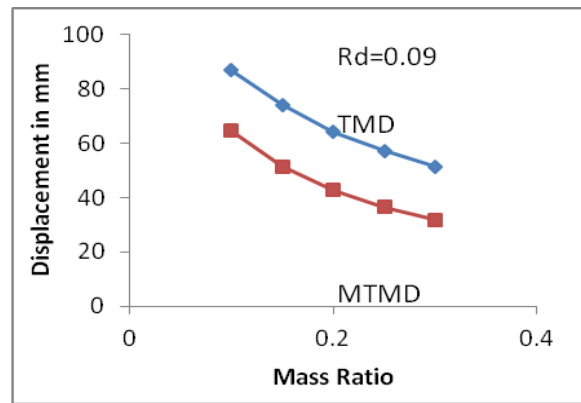

Graph 5 for Rd = 0.09

**C. Tables for Comparative Study of Displacement For Main Structure and Structure with MTMD**

Table 4.3 (I) for mass ratio =0.1

Damping ratio for damper	Displacement due to MTMD in (mm)	%reduction w.r.t Original structure
Rd =0.05	72.5	80.45
Rd = 0.06	68.9	81.40
Rd=0.07	66.5	82.07
Rd=0.08	65.2	82.42
Rd=0.09	64.6	82.58

**Table.4.3 (II) For Mass Ratio =0.15**

Damping ratio for damper	Displacement due to MTMD in ( mm)	% reduction w.r.t Original structure
Rd =0.05	59.2	84.04
Rd = 0.06	55.5	85.040
Rd=0.07	52.3	85.90
Rd=0.08	52.0	85.98
Rd=0.09	51.4	86.145

**Table.4.3 (III) For Mass Ratio =0.20**

Damping ratio for damper	Displacement due to MTMD in mm	%reduction w.r.t Original structure
Rd =0.05	49.9	86.51
Rd = 0.06	46.56	87.45
Rd=0.07	44.4	88.03
Rd=0.08	43.263	88.33
Rd=0.09	42.71	88.48

**Table.4.3 (IV) For Mass Ratio =0.25**

Damping ratio for damper	Displacement due to MTMD in mm	%reduction w.r.t Original structure
Rd =0.05	43.2	88.35
Rd = 0.06	40.719	89.11
Rd=0.07	38.129	89.72
Rd=0.08	37.0289	90.01
Rd=0.09	36.52	90.15

**Table.4.3 (V) For Mass Ratio =0.30**

Damping ratio for damper	Displacement due to MTMD in mm	%reduction w.r.t Original structure
Rd =0.05	38.124	89.723
Rd = 0.06	35.165	90.52
Rd=0.07	33.37	91.00
Rd=0.08	32.36	91.27
Rd=0.09	31.9056	91.40

## V. CONCLUSION

The analyses of vibrations of an ESR structure with TMD Installations, which are tuned to selected modes of vibration, have been studied in this dissertation. The displacements of a structure with MTMD were determined. These calculations were compared with the displacement of the same structure with conventional TMD installed.

1 From the comparative result, it is noticed that, as mass ratio increases from 10% to 30% response or displacement of the structure is also reduced.

2 For Rd = 0.09, MTMD gives 37.96% reduction in displacement than using STMD only. (Table 4.2 V)

3 For the same mass ratio and variation in damping ratio, it has been observed that displacement of the structure reduces using MTMD.

4 For Rd = 0.09 and mass ratio 0.3 gives maximum reduction in displacement and it is 91.40% when compared with original structure. (Table.4.3 V)

5 Hence, from the comparative study it is concluded that using MTMD considering variation in parameters like change in mass ratio, change in stiffness coefficient of, both damper and main structure, we find that MTMD is more effective than STMD.

6 If we increase no of dampers more than 2, the project cost of ESR will increase, so optimum no of dampers to be used.

## REFERENCES

- [1] Dynamics of structure by Anil K Chopra.
- [2] Structural Dynamics by Shrikhande.
- [3] Dynamics of structure by Mario Paz I.S. 1893-2000
- [4] Kefu Liu, Gianmarc Coppola <sup>8</sup> (February 2010)" Optimal design of damped dynamic vibration absorber for damped primary systems "FOR No. 09-CSME-38, E.I.C. Accession 3124.
- [5] Kangming Xu, Takeru Igusa <sup>4</sup> (2 JAN 2007)" Dynamic characteristics of multiple substructures with closely spaced frequencies", Earthquake Engineering & Structural Dynamics Volume 21, Issue 12, pages 1059–1070, 1992.
- [7] M. Abé et al <sup>7</sup>(19 DEC 2006)" Tuned mass dampers for structures with closely spaced natural frequencies" Earthquake Engineering & Structural Dynamics Volume pages 247–261.
- [8] G. B. Warburton <sup>10</sup> (13 DEC 2006) "Optimum absorber parameters for various combination response excitation parameters for systems "Earthquake Engineering & Structural Dynamics , Volume 8, Issue 3, pages 219–236, 1980.
- [9] R. S. Jangid<sup>6</sup>(25 AUG 1999) "Optimum Multiple Tuned Mass Dampers for base-excited undamped system" Earthquake Engineering & Structural Dynamics Volume 28, Issue 9, pages 1041–1049.
- [10] V.A. Bapat et al <sup>9</sup>(24 July 2003)" Effect of primary system damping on the optimum design of an untuned viscous dynamic vibration absorber "Journal of Sound and Vibration Volume 63, Issue 4, 22 April 1979, Pages 469-474 .



**ISSN: 2277-3754**

**ISO 9001:2008 Certified**

**International Journal of Engineering and Innovative Technology (IJET)**

**Volume 1, Issue 6, June 2012**

**AUTHOR BIOGRAPHY**

Prof. S. S. Patil, M.E. (Civil-Structures), Pursuing Ph.D. Head, Civil Engineering Department W.I.T, Solapur (Maharashtra) Chairman of ISSE, Solapur center Research work: Guided more than 10 P.G. students Involved in various Testing & consultancy work.

Mr. S. B. Javheri, M.E. (Civil-Structures) Asstt. Professor in Civil Engineering Department. W.I.T, Solapur (Maharashtra) Member ISSE, Solapur Center.

Prof C. G. Konapure, M.E. (Civil-Structures) P.G. Coordinator (Civil-Structures) W.I.T, Solapur (Maharashtra) Research work: Guiding 4 P.G. students Member ISSE & IEI Solapur, ACCE Solapur Involved in proof consultancy for ESR & R.C.C. structures,