

Analysis of the FFT Performance of the Bipolar SPWM Inverter

Avinash Bajpayee, M. Tech Scholar Truba College of Science and Technology Bhopal

Nilesh Diwakar Truba College of Science and Technology Bhopal

Mithlesh Gautam, Truba College of Science and Technology Bhopal

Meha Shrivastava, Truba Institute of Engineering and Information Technology Bhopal

Abstract – The SPWM inverters are widely used for energy conversion in renewable sources viz. solar power, Wind and bio plants. The paper has evaluated the FFT performance of three different inverting architectures triggered using the sinusoidal pulse width modulation (SPWM). Commonly PWM is used from changing the Gain of the inverter unit. Usually inverters are used for the conversion of DC energy to AC mains for connecting to the grid line. The paper first analyze the performance of the simple IGBT based single phase half wave and full wave inverter without PWM action. In the further architectures, SPWM based Unipolar and Bi polar inverter architectures are evaluated via FFT analysis. All these inverters are implemented and there outputs are described and compared. Simulation results are compared based on the FFT performance and bode analysis using LTI viewer using Simulink. The inverting action is tested fro operating the high voltage AC motors.

Key Words: Power electronics, Insulated Gate Bipolar Junction Transistor, Sinusoidal Pulse width modulation inverter, Linear Time Invariant viewer, Fast Fourier Transform analysis, Simulink.

I. INTRODUCTION

Many researchers have designed different structures for the development of the renewable energy plants. In order to use the renewable energy it is first required to convert the DC energy to AC supply using inverting devices at the front end of systems just followed by solar panels. The inverters are basically classified as half bridge or full bridge inverters. Usually the Thyristor families are used as basic component for designing the various inverting architectures. A full bridge inverter is basic circuit which converts DC to AC power supply. The AC output of full bridge is synthesized from the DC input supply using the closing or opening if the Thyristor switches in appropriate defined sequences. These inverters are used for many applications viz. variable speed AC motors and drives, in UPS's, for HVDC power transmissions, in Electric operated vehicles, and for variable frequency drives.

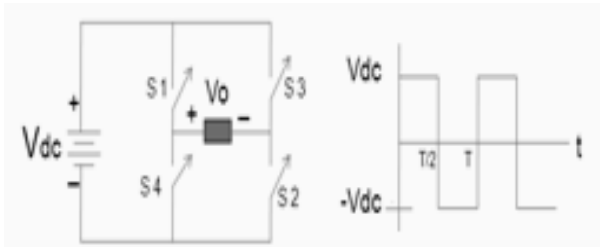

Fig 1. Basic Full wave single phase Inverter circuit

An example of the various kinds of thyristor families used for inverting applications is shown in Figure 2. An example of the basic Full wave Bridge inverter is shown in the Figure 1. The output voltage V_o can be $+V_{dc}$ or $-V_{dc}$, or may be zero based on the thyristor switch is open or closed. It is to be makes sure the sequence in which switches are opened and closed in order to avoid short circuit

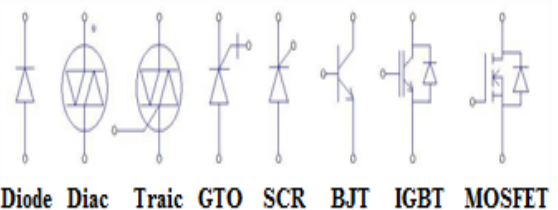

Fig 2 Symbolical representations of various semiconductors

It can be observed from the Figure 1 that switches S1 and S4 must not be on at the simultaneously, similarly switches S2 and S3 must not be on at the same time. These conditions must be neglected to avoid short circuits across the DC source. The thyristor switches don't switch on or off instantaneously. Therefore, switching times must be incorporated during the control of the switches. Overlap of the thyristor switch "on" times may results the source short circuits, also called as "shoot-through" or fault, across the DC mains voltage source. Minimum time allowed for thysistor switching is called as "blanking" time.

In the remaining part of the paper various Inverting architectures are classified in the section II. B2ased on this classification in the section III the existing works are reviewed and problem and challenges are described. Section IV described the basic inverting architectures and there operating principals. In this paper basic IGBT based inverters are described and followed by the working of the sinusoidal Pulse width modulation (SPWM) based polar and Bi-polar inverters.

II. INVERTOR CLASSIFICATION

Broad classification of the inverting architectures is given in the Figure 3. It can be seen that the inverters are broadly classified as polar or Bi-polar inverters. This is based on the 8operating mode of the switches. The Bi-polar inverters may be single phase or three phase inverters.

Uni-polar and Bi-polar are switching methods. In case of the unipolar case output voltage swings between the $=V_d$ to zero as there is only positive voltage thus called

unipolar inverters. While for the Bi-polar inverters the voltage swings from $-V_d$ to V_d with $2V_d$ swing is called as the Bi-polar inverters.

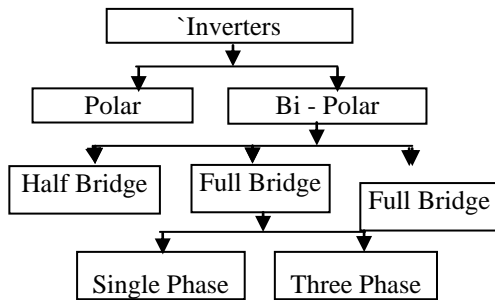

Fig 3 Classification of the image fusion approaches

III. LITTERATURE REVIEW OF INVERTING METHODS

There are many researchers who have designed various architectures of the single phase and three phase inverters. For implementing the inverter many thyristor components along with the basic applications of the PWM for switching are opt by many researchers. Uusually most basic inverter is single phase inverters.

Mohamed A. Ghalib et al [1] have designed and pure sine inverter for the application in the photovoltaic fields. They have proposed a control circuit capable of generating sine waves. Microcontroller (PIC) is used for producing the pure sine wave using PWM. But they have focused on the low power electronic applications as loads. A. I. Andriyanov et al [2] have proposed to use a nonlinear control system for SPWM single phase inverter design. There control was triggered oriented control thus it was dynamic in nature.

Apart from this Anuja Nambodiri et al [3] have compared the performance of the unipolar and Bi-polar PWM inverters. They have described the concept of PWM used for triggering or control of switching devices. Nazmul Islam Raju et al [4] have proposed an SPWM inverter design fro stand alone Micro-grid system. Paper has explained generation of SPWM using Operational Amplifier circuits.

Anubha Gupta et al [5] have proposed architecture of three phase inverter design using the SPWM system design. There system was designed using IGBT's and performance is tested using RL load circuit. The application was used for induction motor speed control. Bijoyprakash Majhi [6] have analyse the performance of the SPWM inverter during their research work they have compared the performance of different PWM techniques used for inverting applications. They have also explained different inverter types as square wave, modified square wave, sine wave inverters.

There are many microcontroller based SPWM methods [7, 8, 9, and 10] were designed to control inverters operation. B Ismail et al [7] have used SPWM technique

in power electronics application for driving the motor or, for the renewable energy system for inverting application.

Usually SPWM switching is generated by using pulses of constant amplitudes having different duty cycles during each time period. Commonly SPWM is generated by comparing the sinusoidal with a triangular waveform as in [11, 12, and 13].

The problem with previous practical inverters is that they have non-sinusoidal waveform suffering for harmonics of since in [14--20]. These harmonics depends upon the number of pulses per cycle. A voltage source inverter using PWM switching is having the input DC voltage abbreviated as $V_{DC} = V_s$ which is usually of fixed magnitude. The principal of inverter is to convert this DC input and to provide us AC output. This is achieved by controlling the frequency and magnitude of the voltage. PWM is used widely for this purpose. There are many methods of PWM generation. The efficiency of an inverter depends on the amount of harmonic distortion reduction and on the switching losses. Since these two parameters depend on the method of modulation technique used for co6ntrolling the inverting action [17]. In the current paper use of the Sinusoidal Pulse Width Modulation (SPWM) method is explore for controlling the inverting action to provide sine output. [18]. SPWM is used to digitize the power by switching on or off the electronic switches. Reasons behind this are its simplicity to implement and capacity of control. Major challenge is the switching losses. Due to these reasons SPWM is adopted for industrial applications such as battery operated electric vehicles and for solar power applications [19].

Objectives: The objectives of this research work;

- To implement and analyse the spectrum and harmonics of various single phase and three phase inverting architecture for high voltage applications.
- Use the SPWM switching control for Inverter designing.
- To compare the performance of the Polar and Bi-polar inverters.

IV. SINUSOIDAL PULSE WIDTH MODULATION TECHNIQUE

During the switching losses the number of pulses used per cycle is also varied. The high end switching technique consumes higher power losses. Following major factor must be meeting to achieve following requirements.

- i. Equipment cost should be low
- ii. The optimum filter size
- iii. Minimum switching power losses.

The major aspect of the Inverter design technology is the nature of the output waveform. Many filters are used to filter out the waveform (viz. quasi sine wave, square wave, or pure sine wave). Commonly capacitors and inductors are mostly used to low pass filter which reduces

the harmonics from the sine wave components. An Inverter is therefore required to control the frequency and magnitude of the output inverting voltage. This is provided by using PWM to operate the inverter switches and hence such inverters are called PWM inverters.

Square wave based switching method produces more harmonic contents in the inverter output wave, as compared to using pulse width modulation switching technique. In SPWM modulation there are multiple numbers of pulse per half cycle are generated in the output and these pulses are also of different width. The principal of the PWM is to vary the width of each pulse with respect to amplitude of sine wave. The PWM signals are generated by comparing reference sinusoidal with a high frequency triangular signal. The AC output voltage is given as;

$$V_o = V_s \sqrt{\frac{pT}{\pi}} \quad (1)$$

Or

$$V_o = V_s \sqrt{\sum_{m=1}^2 \frac{p}{\pi} \frac{T_m}{\pi}} \quad (2)$$

Where; p defines the number of pulses.

T is the width of the pulses

The process of PWM generation is visually explained as shown in the Figure 4.

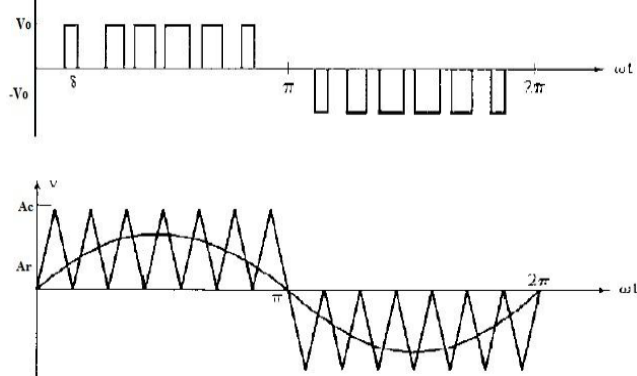

Fig 4 a) SPWM generation Process

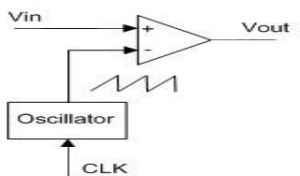

Fig 4 b) Basic PWM Circuit

Why IGBT: There are many electronic switches are available viz. SCR, MOSFETS and IGBT's. The prime advantage of using the IGBT for the inverter design are its capacity to use at high voltage application, it's easy to drive and having low On resistance, also it is used for the high speed stitching required at higher voltage applications.

This is because IGBT provides the Hybrid combination of MOSFET insulating gate and output characteristics of BJT's. Therefore IGBT is voltage

controlled as MOSFETS but output performance is like BJT. This causes fast switching and higher output performance. .

V. SIMULATION OF VARIOUS INVERTING ARCHITECTURES

In this paper three different Inverting architectures using the IGBT switches are validated and analysed. In order to evaluate the harmonic distortion performance the paper analysed the FFT performance of the inverting architectures. MATLAB 2009b SIMULINK is used for implementing the inverting models and then FFT tool is used for plotting and analysing the FFT of the output waves. The first half wave and full wave existing IGBT based SPWM inverters are analysed for the output voltage performance and FFT analysis. The inverting models are given in the Figure 5 and Figure 6 respectively. The output voltage waveforms are compared sequentially in the Figure 7 and Figure 8 respectively for Half and Full wave inverters. It can be observed from the Figure 7 and Figure 8 that the output voltage is better sinusoidal nature and of less harmonic with Full wave inverters. Both these architectures are polar inverter examples.

DC/AC Half-Bridge Inverter

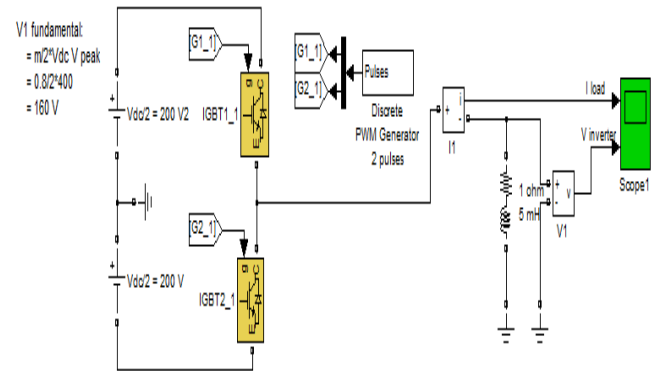

Fig 5 Half Wave Bridge IGBT Inverter

DC/AC Full-Bridge Inverter

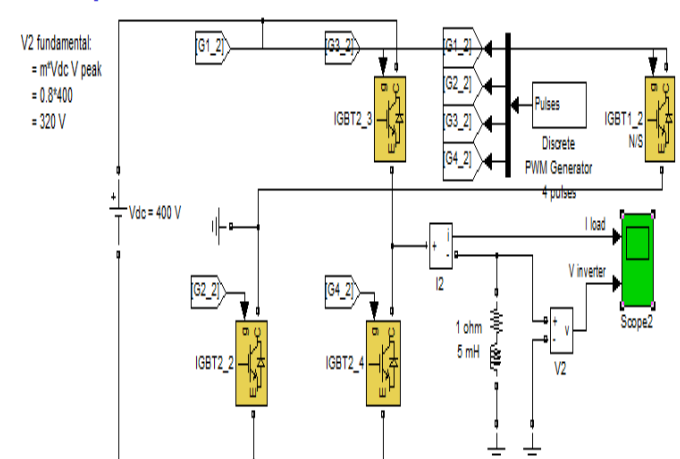

Fig 6 Model for Full Bridge IGBT inverter unipolar

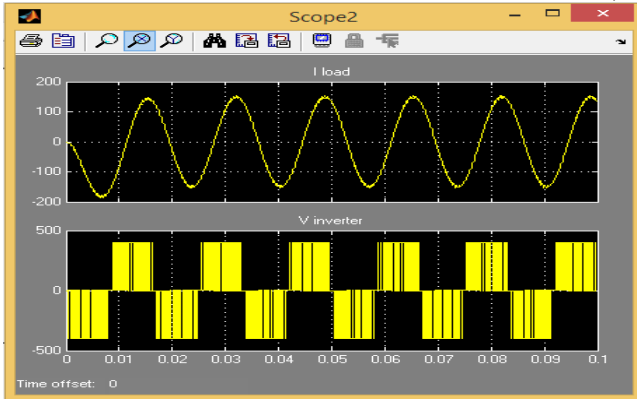

Fig 7 Simulated waveform output of the Single phase IGBT inverter.

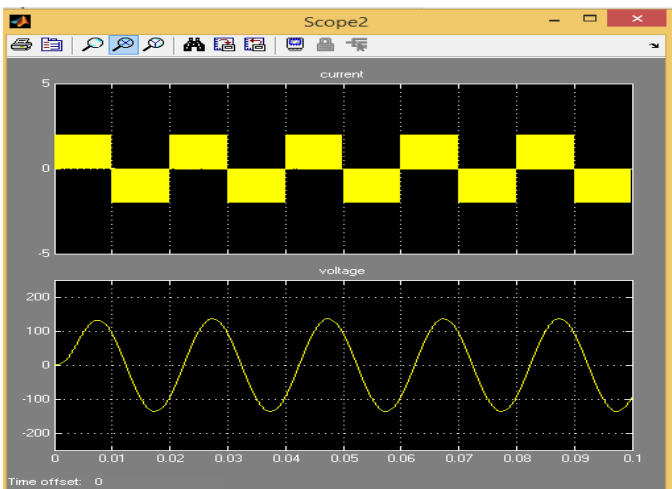
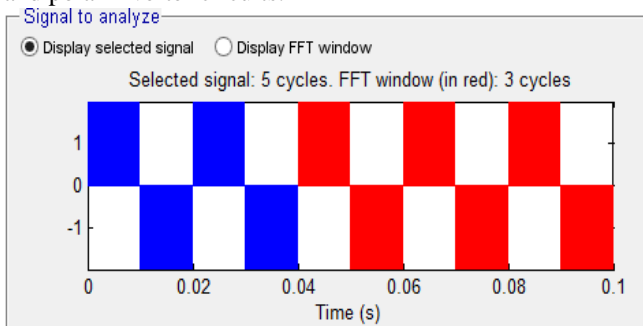
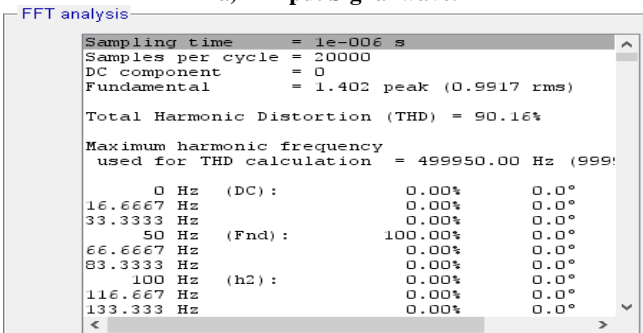

Fig 8 Simulated output of the Single phase IGBT bipolar inverter.

The FFT comparison of both the architecture is compared in the Figure 9 for two cycles of the bipolar and polar inverter circuits.



a) Input Signal wave.



b) Simulation parameters for the FFT plot.

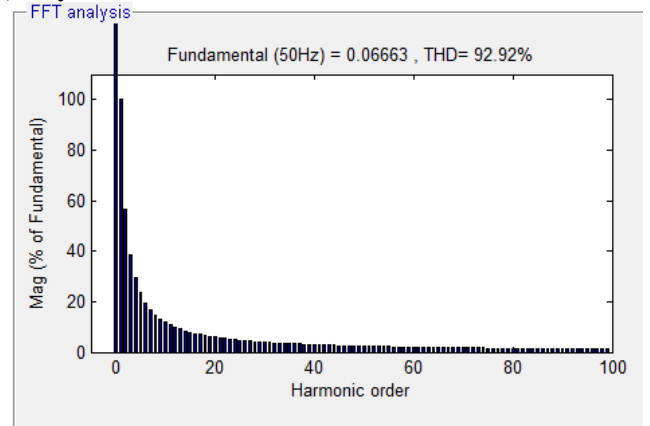

c) FFT for the polar IGBT inverter

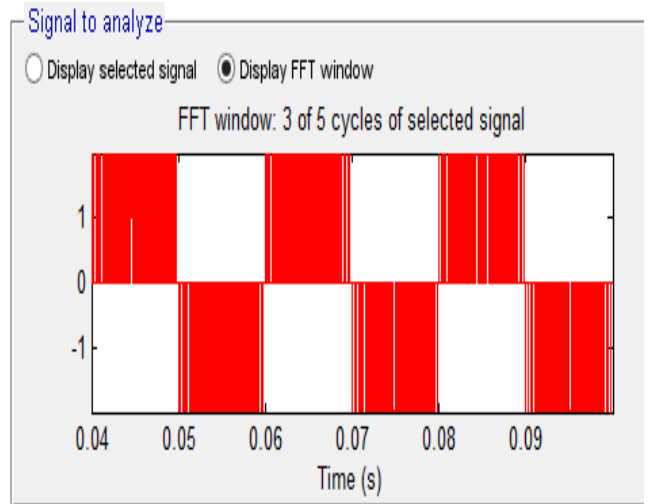

d) FFT window of 3 cycle of signal.

It can be observed from the Figure 9 c) and e) that the FFT describes the spectrum of the output of the bipolar inverter. It can be observed from the outputs that bi-polar FFT is having more harmonics but simultaneously the output is better in terms of the sinusoidal wave response, the bipolar inverters are much

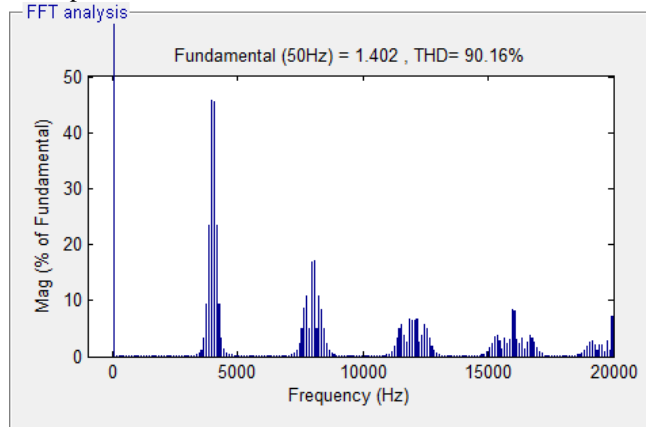

e) FFT in Frequency domain for Bipolar inverter
Fig 9 Result comparison of the FFT analysis for polar and bipolar inverters.

VI. CONCLUSION

This paper the prime concern is to evaluate the performance of the IGBT based inventing architectures in terms of the FFT analysis. The major challenges in

inverter design are the harmonic distortion and maintain the sinusoidal nature of the output. Paper also reviews the various existing paper in the field of the inverter design based on our classification cart. It is found that it is required to analyze the FFT performance for evaluating harmonic distortions. Following major conclusions are drawn from current research paper:

- The inverters are primarily classified as polar and bipolar inverters. The common inverters are designed using the polar IGBT structures.
- In the current work the performance of the Bi-Polar inverters are compared with the polar inverters.
- It is found that the sinusoidal performance of the Bipolar inverters using the SPWM are better than the unipolar inverters.
- Paper also compares the advantages of the IGBT over other kind of similar switches. As our prime concern is to work on the high voltage applications thus IGBT is best choice as it is faster and of higher capacity.
- It is found that the bipolar inverters can be evaluated from more number of cycles as its voltage swings is doubled.
- In future the different IGBT characteristics will be evaluated for inverter performance.

ACKNOWLEDGEMENT

Author here by acknowledges each and every individual who have supported directly or indirectly for the current research and helped the authors. Author also deeply acknowledges all referenced authors to help me understanding the work better from there indirect contributions.

REFERENCES

[1] Mohamed A.Ghalib, Yasser S.Abdalla, R. M.Mostafa, "Design and implementation of a Pure Sine Wave Single Phase Inverter for Photovoltaic Applications" in American society for Engineering Education in 2014.

[2] Maheshri S, Khampariya P , "Simulation of single phase SPWM inverter," IJIRAE Mag., vol. 1, issue 9, Oct. 2014.

[3] Anuja Namboodiri, Harshal S. Wani, "Unipolar and Bipolar PWM inverters", IJRST –International Journal for Innovative Research in Science & Technology| Volume 1 | Issue 7 | December 2014.

[4] Nazmul Islam Raju, Md. Shahinur Islam, Ahmed Ahsan Uddin " Sinusoidal PWM Signal Generation Technique for Three Phase Voltage Source Inverter with Analog Circuit & Simulation of PWM Inverter for Standalone Load & Micro-grid System, International journal of renewable energy research nazmul islam raju et al., vol.3, no.3.

[5] Anubha Gupta- "Three Phase Inverter Simulation using Sinusoidal PWM Technique ", International Journal OF Advanced Research IN Electrical, Electronics AND Instrumentation Engineering Vol. 6, Issue 5, May 2017.

[6] Susmitha Vekkot, and Panoram Shukla, "A Novel Architecture for Wavelet based Image Fusion" Journal of World Academy of Science, Engineering and Technology, Vol. 57, pp. 32-3, 2009.

[7] B Ismil, S Taib, A Saad, M Isa, " development of control circuit for single phase inverter using atmel microcontroller" First IEEE International Conference PEC, p 437-440, November 2006.

[8] S.M Islam, G.M sharif, "microcontroller based sinusoidal PWM inverter for photovoltaic application" First IEEE International Conference development in renewable energy technology, p 1-4, December 2009.

[9] P Zope, P Bhangale, P Sonare, S Suralkar, "design and implementation of carrier based sinusoidal PWM inverter" International Journal of advanced research in electrical, electronics and instrumentation engineering, Vol 1, pp. 230-236, October 2012.

[10] R Senthilkumar, M Singaravelu "design of single phase inverter using dsPIC30F4013" International Journal Engineering Research & Technology (IJERT), Vol 2, pp. 6500-6506, 2012.

[11] D Chauhan, S Agarwal, Suman M.K, Policies For Development Of Photovoltaic Technology: A Review" International Journal of software & hardware research in engineering, Vol. 1, pp. 52-57, December 2013.

[12] A Qazalbash, A Amin, A Manan, M Khalid, "design and implementation of microcontroller based PWM technique for sine wave inverter" International Conference on power Engineering Energy and Electrical Drives, , P 163-167, March 2009, IEEE.

[13] A Mamun A, M Elahi, M Quamruzzaman, M Tomal, "Design and Implementation of Single Phase Inverter" International Journal of Science and Research (IJSR), Vol.2, PP 163-167, February 2013.

[14] L Hassaine, E Olías, M Haddadi, A Malek, "Asymmetric SPWM. used in inverter grid connected" Revue des Energies Renouvelables Vol. 10, pp. 421-429, 2007.

[15] M.N Isa, M.I Ahmad, A.Z Murad, M.K Arshad, "FPGA Based SPWM Bridge Inverter ", American Journal of Applied Sciences, Vol. 4, pp. 584-586, 2007.

[16] Rajesh Kumar Ahuja Amit Kumar "Analysis, Design and Control of Sinusoidal PWM Three Phase Voltage Source Inverter Feeding Balanced Loads at Different Carrier Frequencies Using Matlab, International Journal OF Advanced Research IN Electrical, Electronics AND Instrumentation Engineering Vol. 3, Issue 5, May 2014.

[17] Dutta A, "Some aspects on three phase bridge inverter", IJEI, vol 3, issue 4, pp: 18-21, Nov 2013.

[18] Mathukiya M.G., "three phase inverter with 180 and 120 conduction mode", IJMTER, vol. 4, issue 3, pp. 113-118 ,Mar 2017.

[19] Pankaj H Zope, Pravin G.Bhangale, Prashant Sonare, S. R.Suralkar "Design and Implementation of carrier based SPWM Inverter", IJAREEIE, vol. 1, issue 4, Oct 2012.

[20] B Ismail, S Taib, M Isa, I Daut, A.M saad, F Fauzy, " Microcontroller Implementation of single phase inverter switching strategies" International Conference on Control, Instrumentation and Mechatronics Engineering, p 104-107, May 2007. 2, May 2013.