

# Development of a Finger Rehabilitation Device for Pinching Motion using Pneumatic Actuators

Jun-ya Nagase, Kazuki Hamada, Toshiyuki Satoh and Norihiko Saga  
 Mechanical and Systems Engineering, Ryukoku University

**Abstract**— The paper shows the development of the finger rehabilitation device for pinching motion using pneumatic rubber actuator. It is a low cost, lightweight and portable device to assist the index finger movement for people with limited or no ability to use their hands. The mechanical system consists of the actuator system and the glove. The distal joints are actuated simultaneously by a single air muscle while a second air muscle acts on the metacarpophalangeal (MCP) joints with a minor positive effect on the distal joints. The rehabilitation device is used by very low air pressure of 0.15 MPa. Therefore, it does not require the large compressor system. The developed device was able to conduct the pinching motion. In this paper, we report the mechanism, design and basic characteristics of the developed rehabilitation device.

**Index Terms**—Pinching motion, rehabilitation device, pneumatic actuator, mirroring motion

## I. INTRODUCTION

In recent years, stroke patients are increasing due to the aging of society in Japan, many of these patients have developed a movement disorder such as hemiplegia. In hemiplegia, the therapist helps the rehabilitation, but the number of therapists is much smaller than that of patients. For these reasons, robots which support rehabilitation have been developed [1-10]. These robots move the patient's limbs with paralysis to prevent the contracture of joint.

In a recent study, functional recovery by reconstruction of the neural network and plastic changes in the central neuron is shown in animal experiments of neuroscience and neuroimaging in hemiplegia [11]. Rehabilitation based on the plastic changes of the brain is neuro-rehabilitation. In neuro-rehabilitation, it is important to moving the limbs with paralysis in time the patient intended. In the hand rehabilitation robot that has been developed, these provide only grasp motion because these robots are to prevent the contracture [10]. However, it is also important to do pinching motion to perform activity of daily living.

For this reason, we developed the rehabilitation device which provides pinching motion by index finger and thumb for subject of hand hemiplegia. This device consists of glove, tendon-driven system and tension spring. The tendon-driven system is pneumatic actuator which is lightweight and low-pressure driven [12]. In this paper, we report the construction and driving mechanisms of the developed rehabilitation device.

## II. TENDON-DRIVEN BALLOON ACTUATOR

### A. Driving Mechanism

The pneumatic tendon-driven balloon actuator (balloon actuator) is shown in Fig. 1. The balloon actuator has high power-to-weight ratio and stroke-to-weight ratio [12]. Therefore, it can generate sufficient stroke and force for the driving rehabilitation device. The balloon actuator is driven by compressed air. This actuator consists of a silicone tube (balloon) and a tendon wrapped around a tube. Table 1 shows the balloon specifications. The silicone tube is sealed at one end to produce balloon. Compressed air is supplied through the other end to expand the balloon. The tendon is made of polypropylene. A nylon fiber sheet is adhered to one side of the tendon to decrease the friction force generated between the balloon and the tendon. The expansion axially of the tube was suppressed. The wall is arranged on one side of the balloon to restrain its expansion. To decrease the loss of output efficiency, a roller is arranged in the part where the tendon direction is changed. A basic driving mechanism is presented in Fig. 2 (a) and (b). The tendon wrapped around the balloon is expanded when the balloon expands, which creates tensile force for the tendon drive.

The stroke and the generated power of the tendon-driven system depend on the balloon's expansion and inner pressure. However, the output characteristics of the tendon-driven system can be changed by arranging the tendon, as presented in Fig. 2 (a) and (b). Fig. 2 (a) portrays one end of tendon is fixed. Fig. 2 (b) shows both ends of the tendon are free. Based on structural difference, the type shown Fig. 2 (a) theoretically generates twice the stroke of that in Fig. 2 (b). Fig. 2 (b) theoretically generates twice the power of that portrayed in Fig. 2 (a).

### B. Experimental System

The experimental system is presented in Fig. 3.

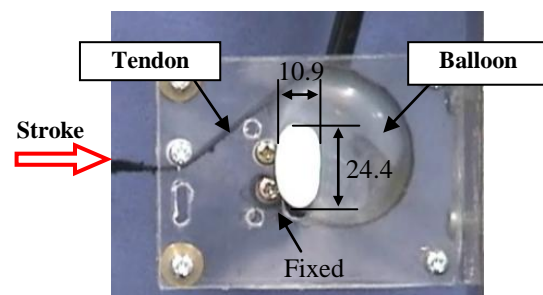

Fig. 1. Tendon driven balloon actuator.

Table 1. Specification of a balloon.

Material	Silicone	
Length	20mm	
	Long diameter	Short diameter
Outer diameter	24.4mm	10.9mm
Inner diameter	21.3mm	7.1mm

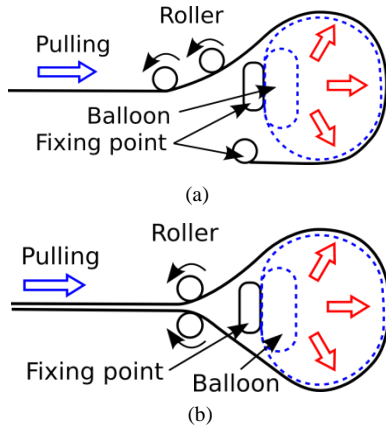

Fig. 2. Configurations of two types of tendon-driven system: (a) long-stroke type and (b) high-power type

In this system the characteristics are measured using the sliding jig, which moves horizontally in the direction of the tendon's pull. The displacement of the sliding jig is measured using a laser displacement meter (IL-S100; KEYENCE). The displacement can be also be limited arbitrarily by positioning the stopper. The generated force after the sliding jig moves to a limited position is measured by a load cell (LUR-A-500NSA1; Kyowa Electronic Instruments) installed between the stopper and sliding jig. The input pressure of the tendon-driven system is controlled by an electro pneumatic regulator (EVT500-0-E2-3; CKD). In addition, each sensor output of displacement, force and pressure is input to the PC through the AD/DA board (Q8-USB; Quanser).

**C. Characteristics of Long-stroke Type**

This subsection describes the characteristics of long-stroke type tendon-driven system. In the tendon-driven system, the generated force of a balloon actuator depends on the inner pressure and contact area between balloon and tendon. Balloon's expansion is suppressed by fixing point. Therefore, the generated force is increased when contact area between balloon and fixing point becomes small.

To confirm this, we conducted experiment using round and halfway long-stroke type balloon actuator shown in Fig. 4 (a) and (b). Fig. 4 (a) portrays wall is arranged one side of long-stroke type to suppress expansion of the balloon. Fig. 4 (b) shows no wall is arranged around of the balloon. In the experiment, the input pressure is set to 0.25 MPa. Then the electro pneumatic regulator is given the voltage stepwise to the target pressure equivalency. The displacement is set to nine conditions changed every 5 mm between 0 and 40 mm.

The generated force for the displacement of both types is presented in Fig. 5. These values are steady-state values in the force response when the tendon-driven systems are given.

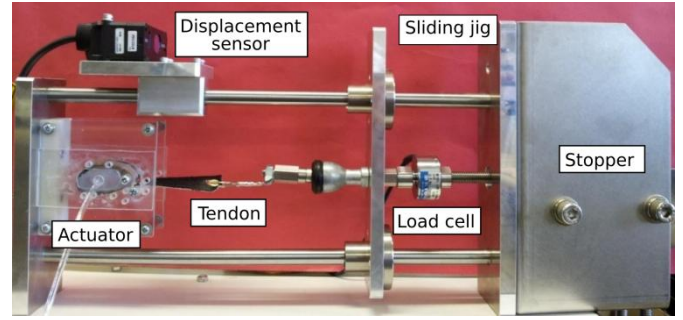

Fig. 3. Experimental system.

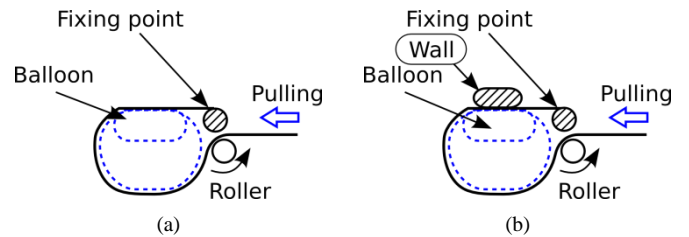

Fig. 4. Long-stroke type tendon-driven system : (a) halfway type and (b) round type.

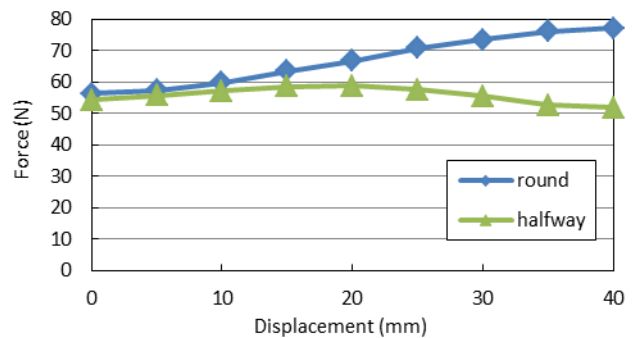

Fig. 5. A relationship between displacement and force of halfway type and round type.

The pressure stepwise after the stroke is limited to a constant length. From the round type result, the generated force is larger than halfway type in each displacement. Therefore, the generated force is increased when contact area becomes small.

From the halfway type result, the generated force decreases with an increase of displacement when the displacement exceeds a certain value. We think this is because when the balloon expands more than certain amount, the balloon is come in contact with roller. The expansion shapes of round and halfway type tendon-driven system are shown in Fig. 6 (a) and (b). Fig. 6 (a) and (b) portrays expansion shapes of halfway and round type when displacement is 20 mm. In the halfway type, balloon is come in contact with roller through the tendon. In contrast, balloon is not contact with roller when displacement is 20mm in round type. Therefore, frictional force between balloon and tendon is increased and the generated force of half type is decreased.

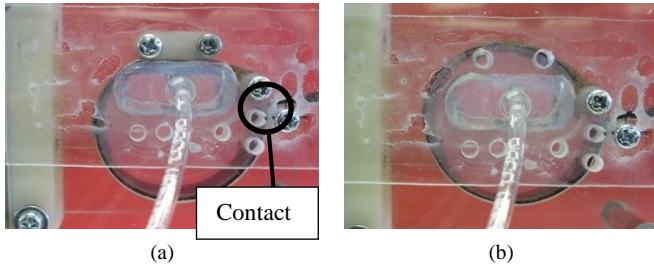

Fig. 6. Expansion shapes of long-stroke tendon-driven system: (a) Halfway type and (b) round type.

**D.Characteristics of High-power Type**

This subsection describes the characteristics of high-power type tendon-driven system. In the high-power type as with the long-stroke type, the generated force depends on the contact area between balloon and tendon. To measure the characteristics depending on the arrangement of the balloon, we conducted the experiment using high-power type A, B and C which are shown in Fig. 7 (a), (b) and (c). The high-power type A is the type which arranges balloon vertically to the tensile force direction and disposes wall length 16 mm. The high-power type B is the type which arranges balloon horizontally to the tensile force direction and disposes wall length of 6 mm. The high-power type C is the type which arranges balloon horizontally the tensile force direction and disposes wall length of 12 mm.

In the experiment, the input pressure is set to 0.25 MPa. Then the electro pneumatic regulator is given the voltage stepwise to the target pressure equivalency. The displacement is set to nine conditions changed every 2.5 mm between 0 and 20 mm.

The generated force for the displacement of each type is presented in Fig. 8. From the result, the maximum generated force of all high-power type is approximately 140 N and there are no large differences between each high-power type. The contact length between balloon and tendon which is determined by image processing is shown in Table 2. The contact length means contact area between balloon and tendon because tendon width is constant. In the contact length, there are no large differences between each type. Therefore, arrangement of balloon does not significantly affect the characteristics.

In the tendon-driven system, the long-stroke type theoretically generates twice stroke of high-power type. The high-power type theoretically generates twice the power of long-stroke type. However, the generated forces of the round type when displacement of 40 mm for that of the high power type when displacement of 20 mm are about 1.8 times. We consider that it is due to the arrangement of the wall. In the high-power type structure, it is necessary to place the wall. Therefore, generated force of high-power type is decreased.

**E.Characteristics of Interior Type**

This subsection describes the characteristics of the interior type tendon-driven system which was applied to a robot hand [13].

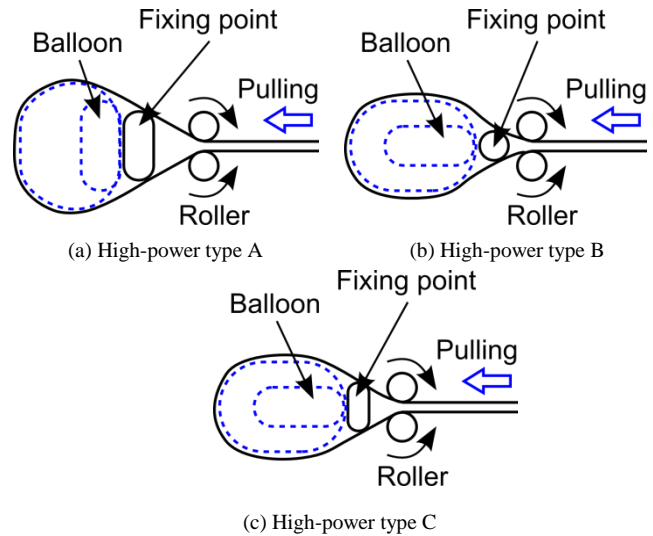

Fig. 7. Configurations of three high-power type tendon-driven system.

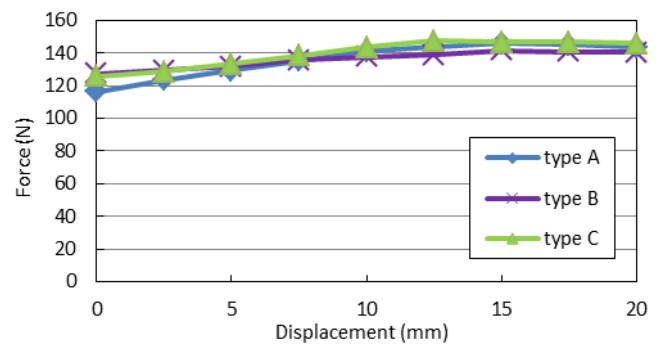

Fig. 8. A relationship between displacement and force of high-power type.

Table 2. Contact length between balloon and tendon of high-power type.

	type A	type B	Type C
Contact length (mm)	102	102	107

The interior type (old type) is one of halfway long-stroke type as shown in Fig.9. The generated force of the interior type is known that it is smaller than halfway type. To improve the efficiency of the generated force, we conducted experiment using old type, interior type A and type B. The type A and type B are shown in Fig. 10 (a) and (b). The interior type A is the type which arranges roller in the part where the tendon direction is changed. The interior type B is the type which changes the construction of the tendon from type A.

In the experiment, the input pressure is set to 0.25 MPa. Then the electro pneumatic regulator is given the voltage stepwise to the target pressure equivalency. The displacement is set to nine conditions changed every 2.5 mm between 0 and 20 mm. The generated force for the displacement of each type is presented in Fig. 11. From the result, generated force of type A and B are larger than old type in each displacement. In the old type, roller is not arranged in the part where the tendon direction is changed. Additionally, tendon is made of

polypropylene and nylon sheet which is adhered.

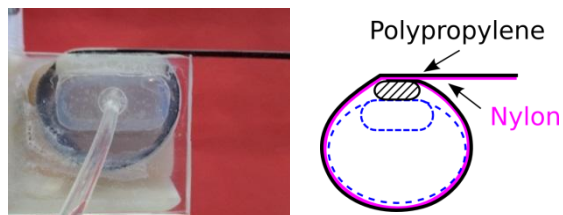

Fig. 9. Interior type tendon driven system (old type).

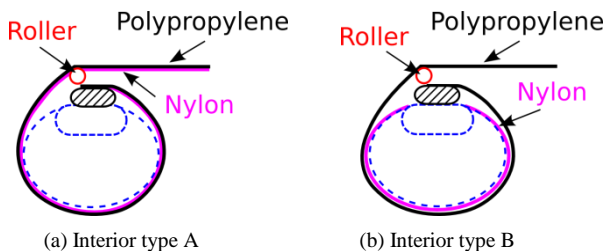

Fig. 10. Configurations of two interior type tendon-driven systems.

The adherent surface of tendon exposes when high pressure is applied to tendon. Because of this, adherent surface of tendon and fixing point are come in contact. Therefore, high frictional force is generated between tendon and fixing point. Consequently, generated force of type A and type B, which arrange roller to decrease frictional force is larger than old type. In the type A and type B, there are no large differences between two types.

Next, we conducted the experiment which applies load. In the experimental system, the tension spring which has a spring constant of 1.0 N/mm with initial force of 5.3 N is arranged in stopper as load. The generated force of each type is shown in Fig. 12. From the result, the generated force of type B is larger than the other type. In the type B, polypropylene and nylon sheet, of tendon is not adhered. Because of this, frictional force between balloon and adherent surface of tendon is decreased when high pressure is applied to tendon. Therefore, generated force of type B is increased from type A. Consequently, frictional force between tendon and fixing point, and frictional force between tendon and balloon affect efficiency of tendon-driven system.

### III. REHABILITATION DEVICE

#### A. Construction and Mechanism

This subsection describes the construction and mechanism of the rehabilitation device we developed. The rehabilitation device makes the operation of the finger pinching motion for patients with hemiplegia. To perform effective rehabilitation, the pinching motions should be naturally. In this study, we use the glove which is arranged wires as mounting portion shown in Fig.13. The wires are arranged on the basis of the arrangement of human tendon. The finger is flexed or extended by pulling the arranged wire. The developed rehabilitation device is presented in Fig. 14. The rehabilitation device consists of the glove, two internal type

tendon-driven systems and two tension springs.

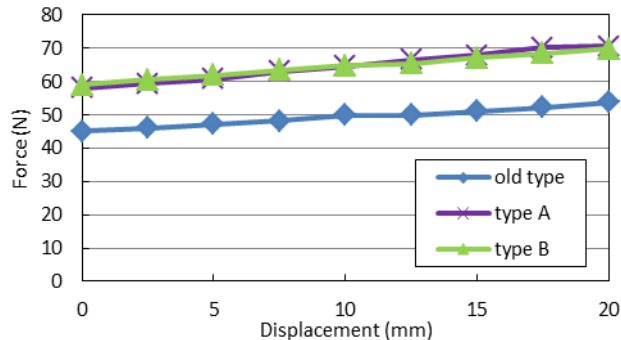

Fig. 11. A relationship between displacement and force of interior type.

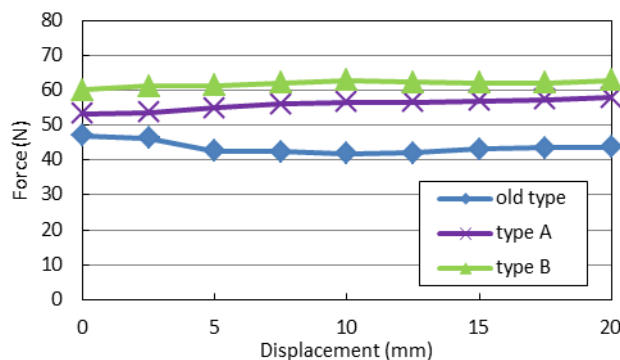

Fig. 12. A relationship between displacement and force of interior type which applied load.

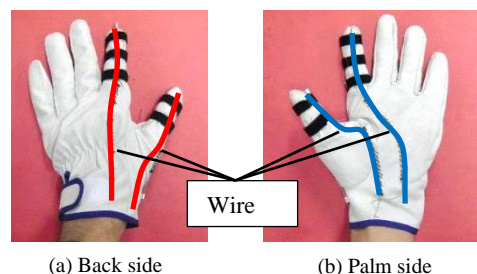

Fig. 13. Mounting portion.

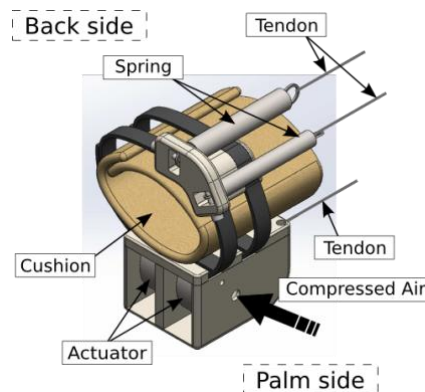

Fig. 14. Construction of rehabilitation device.

It is an antagonistic mechanism of the tendon-driven system and tension spring. The driven mechanism of the device by one-link model is shown in Fig. 15. This is a model of one joint of finger. The finger flexes by tensile force of

tendon-driven system and extends by restoration force of the tension spring.

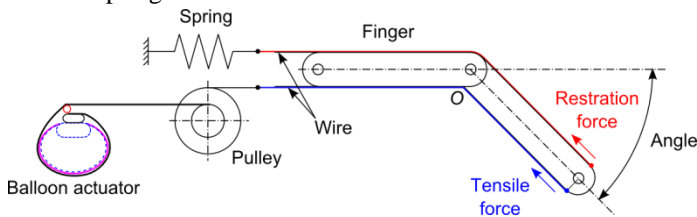

Fig. 15. Driven mechanism of rehabilitation device.

Table 3. Tension spring characteristics.

	Index finger	Thumb
Initial tension	3.84 N	3.38 N
Spring constant	0.386 N/mm	0.338 N/mm
Free length	65 mm	65 mm

To increase the stroke of wire, pulley is arranged between tendon-driven system and mounting portion. The stroke of wire at the fingertip is twice the stroke of the actuator. By these mechanisms, the device can provide pinching motion by the index finger and the thumb.

In the tension spring, restoration force of tension spring should be larger than the force which is required to extend finger. To configure the restoring force of spring, we measured the required force to extend finger in each displacement of wire. The required force is measured by pull tension gauge, and the displacement of wire is measured by scale. The measurement was conducted with three healthy people. On the basis of the measurement result, the spring is configured as Table 3. The maximum value of required force and restoration force of spring for wire displacement is shown in Fig 16 (a) and (b). Fig (a) portrays the required force to extend the index finger and restoration force of tension spring. Fig (b) shows the required force to extend the thumb and restoration force of tension spring. From these figure, the restoration force is larger than the required force in each displacement.

**B. Prototyping and Operation**

This subsection describes the operation of the developed rehabilitation device. The produced rehabilitation device is shown in Fig. 17. The interior type long-stroke tendon-driven system is installed the device. The device can drive at a low air pressure of 0.15 MPa. To verify the operation of the rehabilitation device, we conducted an experiment. In the experiment, a healthy subject wears the device and inputs air pressure to the device. The step response of the device is recorded. The experiment system is shown in Fig. 18. In the experiment, the compressed air that is input to the balloon is provided by air compressor (YC-4; Yaezaki Kuatsu). The air pressure is limited using an air regulator (R301-03; KOGANEI). The compressed air is input to the stepwise by using solenoid-controlled valve (GA010E1; KOGANEI). The one hand of the subject is assumed to paralyzed hand and mounts the glove. The tendon-driven system and tension spring are wound on it. The wire of glove is connected to the tendon-driven system and the tension spring.

The operation of the device is shown in Fig. 19. This is the response of rehabilitation device when compressed air is entered stepwise. The input air pressure of index finger is 0.15MPa, and that of the thumb is 0.12MPa. From the figure, the affected side hand did the pinching motion by using the device.

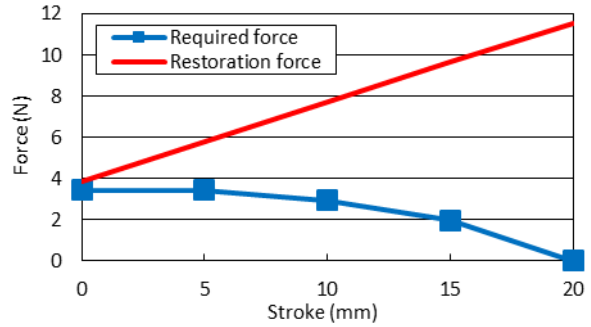

(a) Index finger

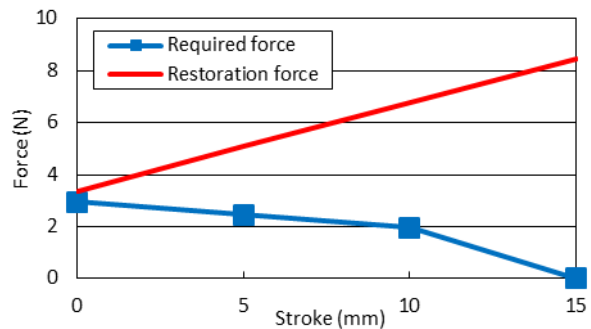

(b) Thumb

Fig. 16. A relationship between wire displacement and tensile force.

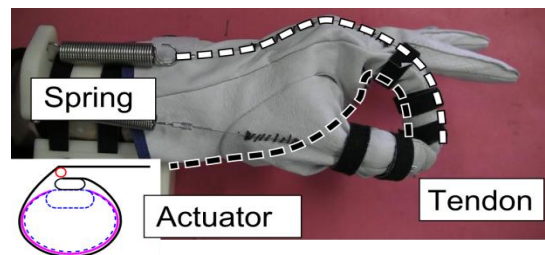

Fig. 17. Prototype of developed rehabilitation device.

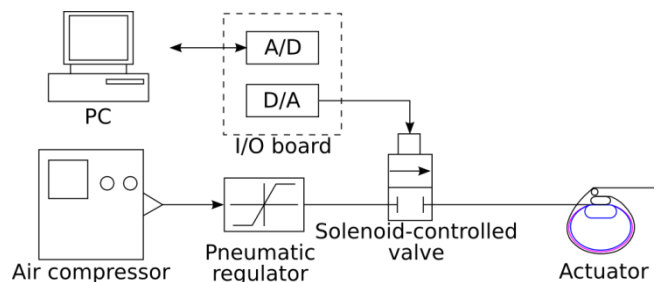

Fig. 18. Experimental system.

**C. Mirroring motion**

Next, we examined mirroring motion performance of the

prototyped device. The mirroring operation is an effective rehabilitation method for restoring motor function. In the mirroring operation, the rehabilitation device moves the hand on the affected side according to the movement of the hand on the unaffected side.

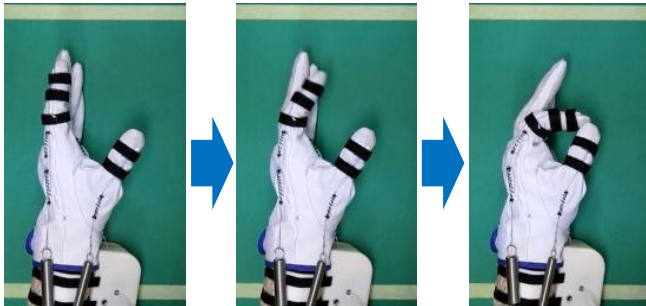

Fig. 19. Pinching motion by the rehabilitation device.

In this study, we conducted a mirroring motion experiment using the prototyped rehabilitation device. The rehabilitation device was worn in affected side hand. The glove with bending sensor was worn in unaffected side hand. In the experiment, the bending sensor measured finger joint angles of unaffected side hand while unaffected side hand conducted pinching motion. Then, the rehabilitation device conducted feedback control to affected side hand in order to do same movement as the unaffected side hand. Fig. 20 depicts the state of the mirroring motion experiment. Fig. 21 depicts the experiment result. By this experiment, we confirmed that the affected side hand moved according to the movement of the unaffected side hand. From Fig. 21, when fingers were extending, the response of the affected side finger was delayed largely for the unaffected side finger motion. This result is caused in the device that does not have actuators for finger extension. Therefore, the response of affected side finger may be improved by installing actuators for finger extension to the device.

#### IV. CONCLUSION

This article described the construction and driving mechanisms of the rehabilitation device. Our conclusions are following:

- (1) The characteristic changes of the tendon-driven system by the winding of the tendon and the arrangement of balloon are evaluated. In the tendon-driven system, contact area between balloon and tendon, and frictional force of tendon affects the efficiency.
- (2) The developed rehabilitation system consists of glove, tension spring and the tendon-driven system. The device provides the finger pinching motion by index finger and thumb for paralyzed hand. The device can drive at low pressure of 0.15 MPa.
- (3) The wire is arranged surface of the glove based on arrangement of human tendon. The finger flexes by tensile force of tendon-driven system. It extends by restoration force of tension spring. Therefore, the device provides human-like pinching motion for paralyzed hand.



Fig. 20. Pinching motion by rehabilitation device.

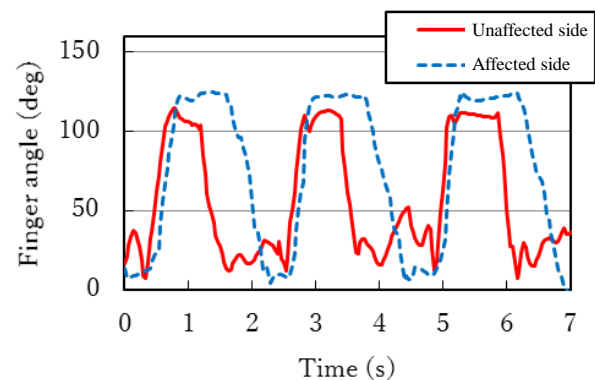

Fig. 21. Transient response of finger angle.

(4) Mirroring motion performance using the prototyped device was examined. In the experiment, the affected side hand was able to move according to the movement of the unaffected side hand. In order to realize a highly responsive mirroring operation, the structure of the device or control systems have to be improved.

#### ACKNOWLEDGMENT

This work was supported by 2015 Ryukoku University Science and Technology Fund.

#### REFERENCES

- [1] K. Suzuki, G. Mito, H. Kawamoto, Y. Hasegawa, and Y. Sankai, "Intension-Based Walking Support for Paraplegia Patients with Robot Suit HAL," *Climbing and Walking Robots*, p.383-408, 2010.
- [2] S.Ueki, Y. Nishimoto, M. Abe, H. Kawasaki, S. Ito, Y. Ishigure, J. Mizumoto, T. Ojika, "Development of Virtual Reality Exercise of Hand Motion Assist Robot for Rehabilitation Therapy by Patient Self-Motion Control," 30th Annual International IEEE EMBS Conference, 2008.
- [3] N. Saga, N. Saito, J. Nagase, "Ankle Rehabilitation Device to Prevent Contracture Using a Pneumatic Balloon Actuator," *International Journal of Automation Technology*, vol.5, No.4, pp. 538-543, 2011.
- [4] D. Sasaki, T. Noritsugu, M. Takaiwa, "Development of Active Support Splint driven by Pneumatic Soft Avtuator (ASSIST)," *Proceedings of the 2005 IEEE International Conference on Robotics and Automation*, 2005.
- [5] Y. Yin, Y. Fan, L. Xu, "EMG and EPP-Integrated Human-Machine Interface Between the Paralyzed and Rehabilitation Exoskeleton," *IEEE Transactions on*

Information Technology in Biomedicine, vol. 16, no. 4, pp. 542-549, 2012.

- [6] Z. Bien, D. kim, M. Chung, D. Kwon, P. Chang, "Development of a Wheelchair-based Rehabilitation Robotic System (KARES II) with Various Human-Robot Interaction Interfaces for the Disabled," Proceedings of the 2003 IEEE/ASME International Conference on Advanced Intelligent Mechatronics, 2003.
- [7] M. Takaiwa, T. Noritsugu, "Development of Wrist Rehabilitation Equipment Using Pneumatic Parallel Manipulator," Proceedings of the 2005 IEEE International Conference on Robotics and Automation, 2005.
- [8] L. Masia, H. Krebs, P. Cappa, N.Hogan, "Design and Characterization of Hand Module for Whole-Arm Rehabilitation Following Stroke," IEEE/ASME Transactions on Mechatronics, vol. 12, no. 4, pp. 399-407, 2007.
- [9] H. Krebs, B. Volpe, D. Williams, J. Celestino, S. Charles, D. Lynch, N. Hogan, "Robot-Aided Neurorehabilitation: A Robot for Wrist Rehabilitation," IEEE Transactions on Neural Systems and Rehabilitation Engineering, vol. 15, no. 3, pp. 327-335, 2007.
- [10] H. Kawasaki, S. Ito, Y. Ishigure, Y.Nishimoto, T.Aoki, T.Mouri, H.Sakaeda and M. Abe, "Development of a Hand Motion Assist Robot for Rehabilitation Therapy by Patient Self-Motion Control," Proceedings of the 2007 IEEE 10th International Conference on Rehabilitation Robotics, 2007.
- [11] F. Hummel, L. Cohen, "Drivers of brain plasticity," Current Opinion in Neurology, vol. 18, pp. 667-674, 2005.
- [12] J. Nagase, N. Saga, "Two tendon-driven systems using pneumatic balloons," Advanced Robotics, vol. 25, No. 9-10, pp. 1349-1361, 2011.
- [13] J. Nagase, N. Saga, T. Satoh, K. Suzumori, "Development and Control of a Multifingered Robotic Hand Using a Pneumatic Tendon-driven Actuator," Journal of Intelligent Systems and Structures, vol. 23, no.3, pp. 345-352, 2012.