

Frequency Stability Enhancement of DG Based Power Systems using a novel Controller

M.A.El-dabah, M.I. Akar, M.M.El-gazzar, S.othman

mahmoudeldabah@yahoo.com, D_eng2009@yahoo.com, m.elgazzar45@yahoo.com, elsaid_otman@yahoo.com

Abstract—Conventional vast synchronous generators comprise rotating inertia due to their rotating parts. These generators are capable of injecting the kinetic potential energy preserved in its rotating parts to power grid during disturbances or sudden changes. Therefore the system is robust against instability. On the other hand, penetration level of Distributed Generation (DG) units in power systems is increasing rapidly. A power system with a big portion of inverter based DGs is prone to instability due to lack of adequate balancing energy injection within the proper time interval. The solution can be found in the control scheme of inverter-based DGs. By controlling the switching pattern of an inverter, it can emulate the behavior of a real synchronous machine. In Virtual Synchronous Generator (VSG) control technique, the power electronics interface of DG unit is controlled in a way to exhibit a reaction similar to that of a synchronous machine to a disturbance. In this paper the effect of using VSG controller is investigated through many test cases.

Index Terms—Virtual Synchronous Generator (VSG), Distributed Generation (DG), Phase Locked Loop (PLL), swing equation.

I. INTRODUCTION

The earlier designed power systems are based on centralized power generation and unidirectional power flow. These conventional grids comprises vast synchronous generators which are fuelled by fossil fuels. The worldwide concern about environmental pollution, steady depletion of fossil fuels and the increased demand of electrical energy requires an unconventional solution to these problems. So, the research is directed towards the renewable energy resources as an alternative source for electricity generation. Over the last few years, a number of influences have been combined to lead to increased interest in the use of small-scale generators connected to local distribution systems, which is commonly called 'Distributed Generation' (DG). These DGs utilize renewable resources such as wind turbines, photovoltaic, biomass, small hydro-turbines... etc. Beside their environmental benefits, DGs offer a low-cost way for the energy flow into the market since they do not imply substantial transmission losses due to their location near to the customers [1]. Moreover, they could present a reliable and uninterrupted source for the customers especially in rural areas [2] and micro grids [3]. In

addition, a possibility where the DG could be beneficial if it could help to supply load during contingencies until the utility can build up additional delivery capacity [4].

In recent years the capacity of grid connected distributed generation via inverters is rapidly growing. The Egyptian government has planned to have 20% of the energy generation from the renewable energy by the year 2020 [5]. Moreover, the Egyptian government planned to connect 3500 MW from solar energy and 2090 MW from wind energy to the Egyptian unified grid in 2027. Due to their intermittent nature, a power converters (i.e. Inverters) on its front end is required when the DGs based on renewable energy resources are connected to the AC grid to meet the grid requirements. The inverters used in distributed generators are controlled using PLL (Phase Locked Loop) in order to be synchronized with power system frequency. Power systems may become unstable, if the capacity of inverter type distributed generators become larger and larger, because inverter frequency is controlled just to follow grid frequency and they have no inertia [6].

A solution towards stabilizing such a power system within the limits of presently available system control strategies is to provide additional virtual rotational inertia. Principally, this can be attained by adding short-term energy storage to any DG unit together with an intelligent control of the power electronic interface to the grid. The DG unit will then operate like a virtual synchronous generator (VSG), exhibiting some of the desired properties of synchronous machines for short time intervals [7]. There are several control methods which are used to emulate the electrical behavior of synchronous machine in the electrical grids. However, their different topologies and distinctive labels, they are common in mimicking the rotational inertia and damping properties of synchronous machine. All of these controllers are reviewed and classified according to its used references and control scheme in Refs. [9, 10].

II. VIRTUAL SYNCHRONOUS GENERATOR (VSG) CONTROL CONCEPT

The VSG control method is based on the known swing equation of synchronous generator which is expressed as in Eq. (1):

$$P_{in} - P_{out} = J\omega_m \frac{d\omega_m}{dt} + D(\omega_m - \omega_{ref}) \quad (1)$$

Where P_{in} represents the prime mover power, P_{out} is the electrical power output from the generator. The moment of inertia and damping factor take symbols J and D respectively. In synchronous generator, the inertia plays an important role as it can contribute to the stable operation of grid through absorption to and release from the inertial energy when transient difference in demand and supply of the grid is occurred. Each synchronous generator converts a part of the kinetic energy stored in its rotating mass to active electric power to supply the required total active power, resulting in a slight decrease of the rotational speed and the frequency of the output voltage. Moreover, the damper windings in the rotor of synchronous generator is used to damp out the rotor oscillation when its speed deviate from synchronous speed. Due to the previous merits of the existence of synchronous generators in the electric grid, the inverter which interface the DG/renewable energy resources will be controlled in the same manner.

III. VIRTUAL SYNCHRONOUS GENERATOR MODELING

The structure of the VSG control block diagram is as shown in Fig. 1. P_{VSG} represents the VSG output power which is injected or absorbed from the grid. P_{ref} is the reference electrical power output from the VSG in steady state condition. The extrinsic (virtual) moment of inertia (J) and damping factor (D) are emulated by the existence of the battery storage. Firstly, P_{VSG} and Q_{VSG} are calculated using the monitored grid voltage parameters i.e. Voltage magnitude, frequency and its rate of change as shown in Eq. (2, 3) [11]:

$$P_{VSG} = P_{ref} + J\omega \frac{d\omega}{dt} + D(\omega - \omega_{grid}) \quad (2)$$

$$Q_{VSG} = K_V (V_{actual} - V_r) \quad (3)$$

Then, the reference current for the current controller in dq-axis are calculated using P_{VSG} and Q_{VSG} values as given in Eq. (4). The PI current controller is used to control the VSG output current and provide the reference voltage for the Sinusoidal Pulse Width Modulation (SPWM).

$$\begin{bmatrix} I_{dref} \\ I_{qref} \end{bmatrix} = \frac{1}{V_d^2 + V_q^2} \begin{bmatrix} V_d & -V_q \\ V_q & V_d \end{bmatrix} \begin{bmatrix} P_{ref} \\ Q_{ref} \end{bmatrix} \quad (4)$$

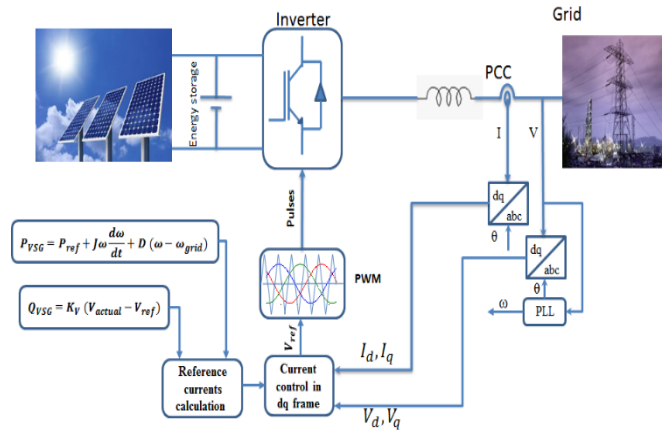

Fig. (1): Schematic diagram of VSG control.

IV. PHASE LOCKED LOOP

The phase locked loop (PLL) technique is used for synchronization of grid-interfaced converters. Also the PLL algorithm is used to monitor the grid voltage parameters (i.e. the voltage magnitude and frequency). Moreover, it is used to provide the phase angle of the grid voltage. There are several techniques to implement the PLL. The commonly used technique is the Synchronous Reference Frame phase locked loop or (SRF-PLL) is shown in Fig (2). The SRF-PLL is broadly used due its good performance when the grid voltage is balanced and not distorted.

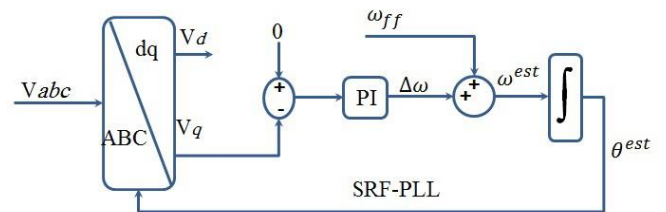

Fig (2). Block diagram of SRF-PLL

V. CASES STUDY

This section will investigate the effect of using the VSG control technique in the electric grid through three cases as following:

A. Case (1)

In this case the effect of VSG solution towards grid frequency stabilization will be investigated. The test network is as shown in Fig. (3). It is composed of three generators of equal rating 100 VA. A three phase transformers are connected to the generators to step up the generated voltage from 380 V to 11000 V. A variable active load with variation cycle as shown in Fig (4) is connected at bus number three to simulate disturbance. The VSG and generators parameters are listed in the appendix in Table.1 and Table.2 respectively.

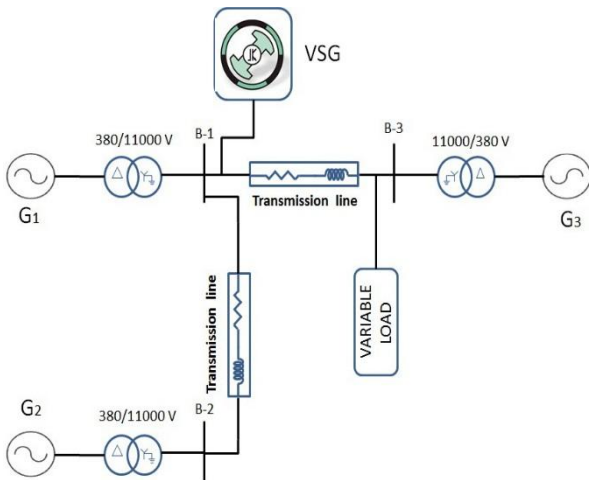

Fig. (3): Test network with VSG connected at Bus 2.

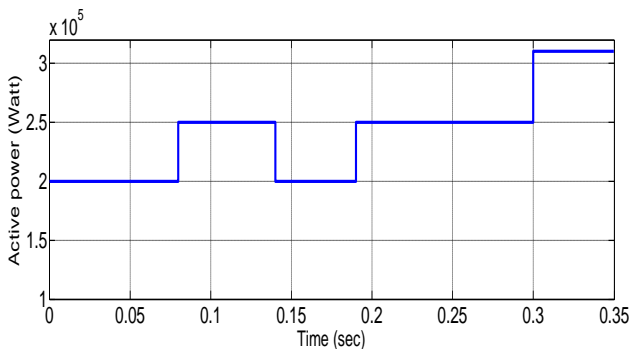

Fig. (4): Load variation cycle.

The simulation results is shown in Fig (5). It is noticed that the VSG reduces the frequency deviation from 2.286 Hz to 1.28 Hz. So, the VSG controller is capable of adjust the frequency level in the grids to be in its acceptable limits.

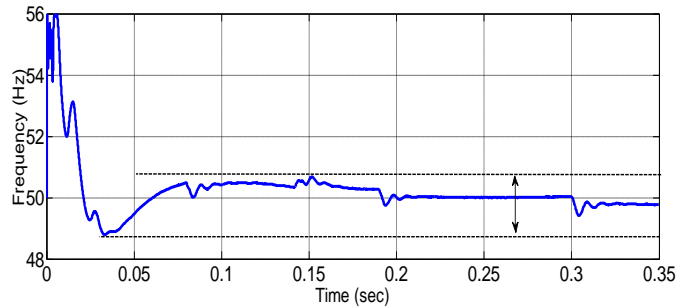

Fig. (5), (A): Load frequency with VSG connected

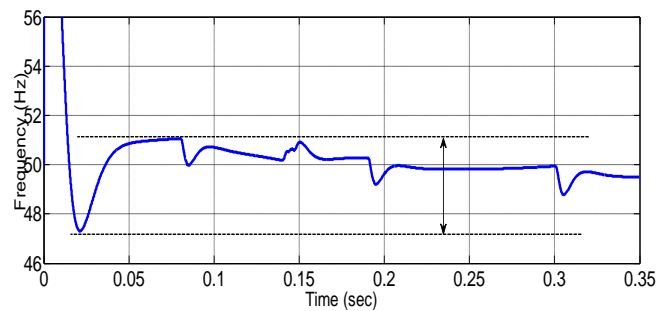

Fig. (5), (B): Load frequency with VSG disconnected

A. Case (2)

Another case study is simulated to investigate that if the VSG can replace the SG and do its function. The test network is as shown in Fig (6). Generator G3 is removed and A 150 KW VSG is connected at bus 3. The same load variation as in previous test is used as a disturbance. The results shown in Fig. (7), indicate that the VSG is capable of emulating the existence of SG in the electrical grid. Also, the frequency variation is in the acceptable rang (i.e. $49 \leq f \leq 51$).

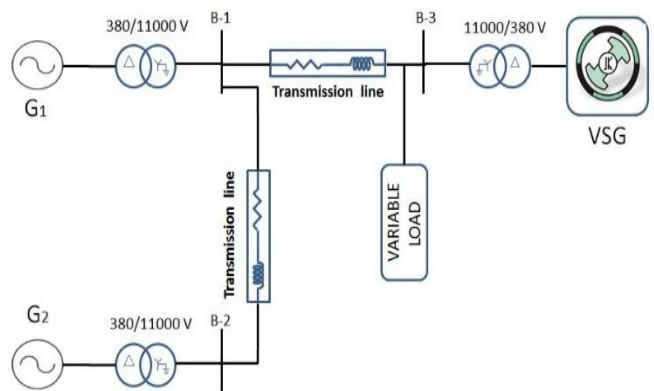

Fig. (6): Test network with G3 replaced by VSG at Bus 2

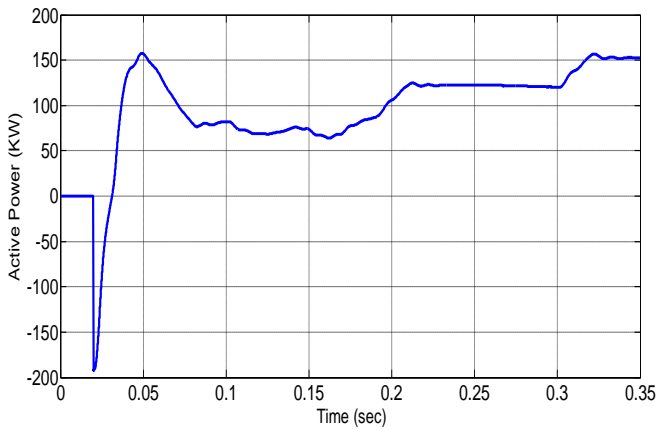

Fig. (7), (A): VSG output power.

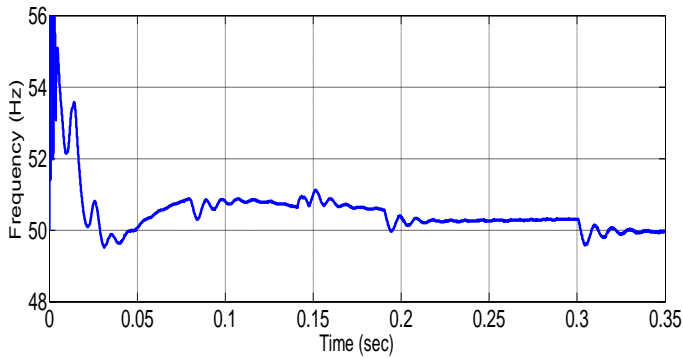

Fig. (7), (B): Load frequency.

B. Case (3)

In Fig. (8), another test scenario is simulated to investigate the connection effect of 100 KW VSG when it operates with a SG having the same VSG rating. A load variation cycle as shown in Fig. (8) Is used as a disturbance to show its effect on frequency profile.

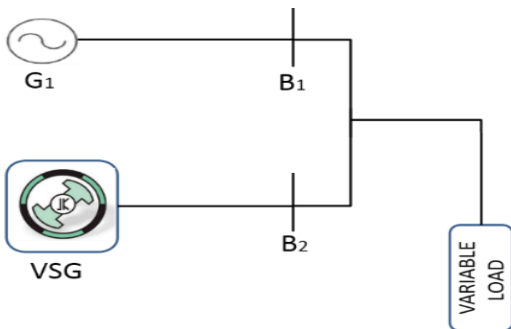

Fig. (8), (A): Test network and load variation cycle

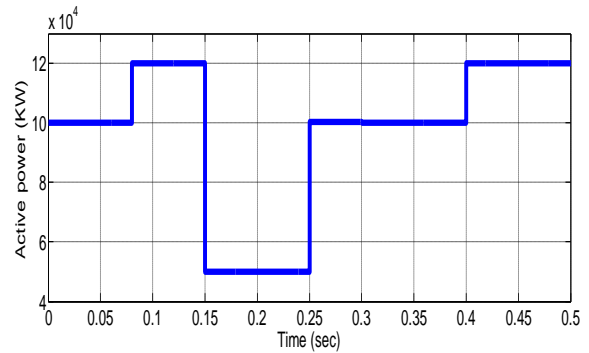

Fig. (8), (B): load variation cycle

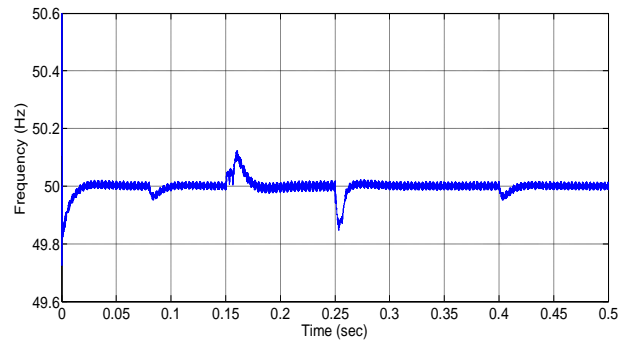

Fig. (8), (C): loadfrequency

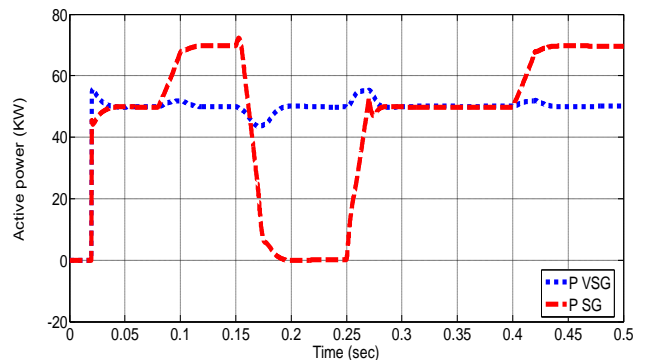

Fig. (8), (D): VSG output power

At first, the load active power is 100 KW and the load frequency is equal 50 Hz. At .08 sec the load increased to be 120 KW. The VSG provide 52 KW according to the rate and value of frequency deviation. This power sharing from VSG helps to restore load frequency to its rated value (i.e. 50 Hz). The load frequency increased to be 50.1 Hz at .16 sec due to switching off 70 KW from the connected loads. The VSG try to decrease the power delivered to the connected load to adjust load frequency. The same procedure is continued till the rest of simulation to verify the ability of VSG to keep the load frequency constant at its rated value.

VI. CONCLUSION

The concept of using Virtual synchronous generation as a method for frequency stabilization is introduced. The effectiveness of the proposed method to stabilize load frequency is investigated through many test scenarios. The simulation results show the feasibility of the control strategy.

VII. APPENDIX

Table .1.Synchronous generators parameters.

Description	Value
Rating	100 KVA
Terminal voltage	380 V
Synchronous speed	1500 RPM
Nominal frequency	50 Hz
Inertia	20 Kg.m ²
d-axis synchronous reactance X_d	2.0 pu
Transient reactance X_d'	0.17 pu
Subtransient reactance X_d''	0.12 pu
Transient reactance X_q'	1.01 pu
Subtransient reactance X_q''	0.15 pu
Leakage reactance X_l	0.06 pu

Table .2. VSG parameters.

Description	Value
Rating	100 KVA
Terminal voltage (line value)	380 V
DC link voltage	750 V
Nominal frequency	50 Hz
Inertia	15 Kg.m ²
Damping coefficient	5500 W sec/rad
Filter inductance	460 μh
Filter capacitance	55 μf

REFERENCES

- [1] G. Joos, B.T Ooi, D. McGillis, F.D. Galiana, and R. Marceau, "The potential of distributed generation to provide ancillary services," at IEEE Power Engineering Society Summer Meeting, 16-20 July 2000, vol. 3, pp. 1762 – 1767.
- [2] M. A. Kashem, and G. Ledwich, "Improvement of power supply to Rural Customers via Grid Interactive Distributed Generation," in International Journal of Global Energy Issues, vol. 26, no 3-4, 2006, pp. 341–360.
- [3] N. L. Soutlanis, S. A. Papathanasiou, and N. D. Hatzigiargyriou, "A Stability Algorithm for the Dynamic Analysis of Inverter Dominated Unbalanced LV Microgrids," in IEEE trans. on Power Systems, vol. 22, no. 1, Feb. 2007, pp. 294 – 304.
- [4] T. E. McDermott, and R. C. Dugan, "PQ, Reliability and DG," in IEEE Industry Applications Magazine, September/October 2003, vol. 9, no. 5, pp. 17 – 23.
- [5] New and Renewable Energy Authority annual reports available at: http://www.moee.gov.eg/english_new/home.aspx
- [6] K. Sakimoto, Y. Miura and T. Ise: "Stabilization of a Power System with a Distributed Generator by a Virtual Synchronous Generator Function", 2011 8th IEEE International Conference on Power Electronics – ECCE Asia, pp. 1498 – 1505(2011).
- [7] T.Vu Van, K. Visscher, J.Diaz, V.Karapanos, A.Woyte, M.Albu, J.Bozelie, T. Loix, D.Federe nciuc, "Virtual Synchronous Generator: An element of future grids", 2010 IEEE PES Innovative Smart Grid Technologies Europe, October 11-13, Sweden.
- [8] Shintai T, Miura Y, Ise T. Reactive power control for load sharing with virtual synchronous generator control. In: 7th IEEE Int. power electronics and motion control conf. – ECCE Asia 2012. Harbin, China; June 2012. p. 846–53.
- [9] S. D'Arco, J.A. Suul, Virtual Synchronous Machines – classification of implementations and analysis of equivalence to droop controllers for microgrids, in: Proc. of IEEEPowerTech Grenoble 2013, Grenoble, France, 16–20 June 2013, 2013, 7 pp
- [10] H. Bevrani, T. Ise, Y. Miura, Virtual synchronous generators: a survey and new perspectives, Int. J. Electr. Power Energy Syst. 54 (2014) 244–254.
- [11] Karapanos V, Yuan Z, de Haan S. SOC maintenance and coordination of multiple VSG units for grid support and transient stability. In: 3rd VSYNCworkshop. Cheia, Romania; June 2010.

Mahmoud El-dabah received the B.Sc. Degree from the Electrical Eng. Dept. Of AL-AZHAR University, Egypt, in 2007 and M.Sc. degree from te Electrical Engineering Department of AL-AZHAR University, Cairo , Egypt in 2012. At present, he is the PhD student at AL-AZHAR University, Egypt. His fields of interest are Power System Stability, Power Electronics, and Distributed Power Generation.

M.I.AKAR is an associate professor of electrical power system at AL-AZHAR University in Egypt.His fields of interest are Power System Stability, renewable energy integration in power systems.

M.M.El-gazzaris a professor of electrical power engineering at AL-AZHAR University in Egypt. His fields of interest are Power System Stability, Artificial intelligence, renewable energy integration in power systems.

S.A.Othman is a professor of electrical power engineering at AL-AZHAR University in Egypt. His fields of interest are Power System Stability, Artificial intelligence, renewable energy, power systems control.