

A Compact L-probe feed Water-based patch antenna

Manish R. Deshmukh, Department of Electronics and Communication technology Vivekanand Polytechnic, Sindhi society, Chembur, Mumbai-400074, India

Prof. Dr. R.K. Kulkarni, Department of Electronics and Telecommunication Engineering Vivekanand Institute of Technology HAMC, Collector's Colony, Chembur, Mumbai-400074, India

Abstract— An innovative water dense dielectric patch antenna fed by L-probe is proposed and investigated. The operation mechanism of the water DDPA perform similar to the conventional rectangular metallic patch antenna operated in the fundamental TM₁₀ mode. An L-shape probe is used to excite water DDPA in order to observe bandwidth performance of antenna by selecting the thick high relative permittivity supporting substrate in between the ground plane and the water patch. The water DDPA operated at 1.025 Ghz exhibit maximum impedance bandwidth of 22.8%, maximum gain of 7.48 dBi, radiation efficiency up to 70% and symmetrically unidirectional radiation pattern with low back lobe and low cross polarization level. Performance of this DDPA is observed with different dimensions and patch material (normal and sea water), simulated results are investigated.

Index Terms— L-probe, water patch, dense dielectric patch antenna.

I. INTRODUCTION

Different liquid materials, such as mercury [1], [2], eutectic gallium indium (EGaIn) [3], liquid crystal [4], [5], and water [6], [7], have been utilized for realization of antennas owing to their many interesting properties, such as liquidity, transparency, and so on. Among these materials, water has become the most popular one recently because of low cost, easy access, and safety. Generally, the use of water for designing antennas can be divided into two kinds—the salt water and the pure water. The salt water is usually used as a conductor to support current flow. Different water monopoles have been designed based on this idea [8], [9]. On the other hand, the pure water is commonly applied as a dielectric to construct dielectric resonator (DR) antennas [10]–[11]. However, the high dielectric loss of the water degrades the radiation efficiency of these antennas.

Now days the dense dielectric patch antenna is designed [12], as compare to conventional metallic patch antenna the metallic patch is replace with water patch with high dielectric constant. The waves can be trapped between the dielectric water patch and ground plane because of high permittivity of dielectric patch as compare to supporting ground plane. The result [12] shows that the cavity mode is excited between dielectric patch and ground plane.

At the room temperature the pure water is dielectric with very high permittivity at microwave frequency. The water

patch is used for providing the boundary condition similar to electric wall, the required cavity mode can be excited.

The L-probe feeding technique is used to feed water patch, its indirect method for feeding the antenna which is widely used in conventional metallic patch antenna [13]. The L-probe feed provided the simplicity of fabrication for the design because of it can't be physically connected to the water patch. Section II describe the geometry and design consideration of antenna.

II. ANTENNA DESIGN

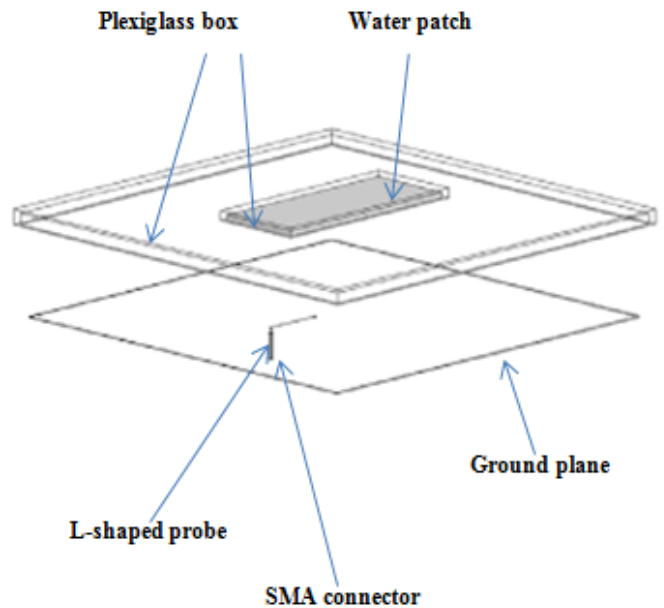

Fig. 1. Geometry of the L-probe fed water dielectric patch antenna [14]

The geometry of proposed water dense dielectric patch antenna as shown in Fig.1.

It consists of two plexiglass box stacked together, the thickness of plexiglass is 0.4 mm and dielectric constant is 3.4. The top box having a length of L_p , width of W_p and height H_p is filled with pure water, while bottom larger box is empty and its act as a supporting to the structure. The substrate between the water patch and the ground plane is air. The square metallic ground plane having length W_g placed at the bottom of larger plexiglass box where the L-shape probe is mounted. The height and length of L-shaped probe is L_v and L_h respectively. S is the spacing between the edge of water patch and position of L-shaped probe. [14]

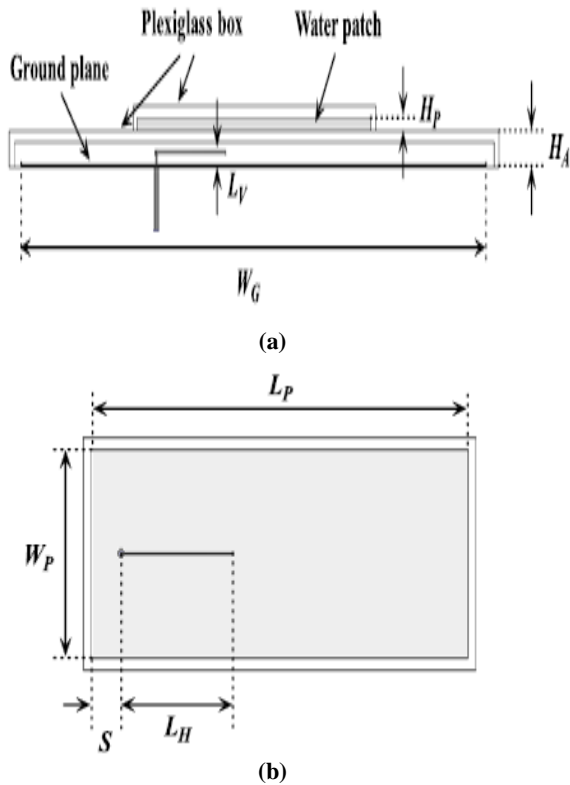

Fig. 2. Geometry of the L-probe fed water dielectric patch antenna (a) Side view (b) Top view [14]

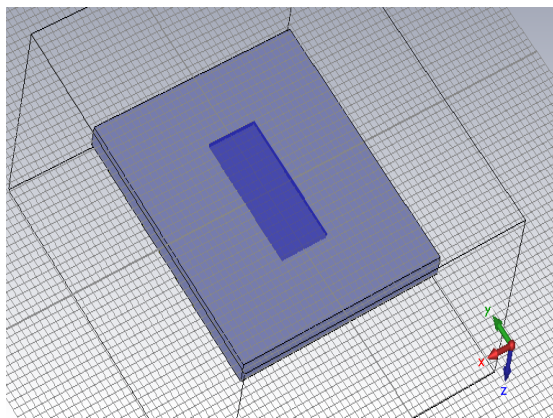

Fig. 3. Model design in CST studio

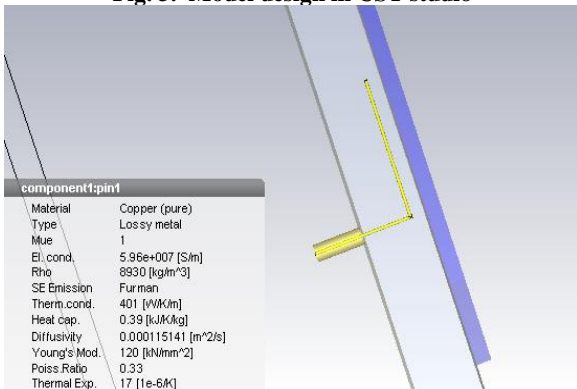

Fig. 4. Side view of model design in CST studio

The proposed antenna model is design in CST Studio 2015 as shown in Fig. 2. It consist of water patch, air substrate and metallic ground plane having L-shape probe with SMA connector for feeding the antenna. For design of SMA connector consist of pin is pure copper coated with dielectric material Teflon. The L-shape probe is design to the intersection of two pure copper pin. For design antenna model select the appropriate material from library to the different component used in the antenna. According to result [13] the aperture coupled DDPA with a thin substrate has a narrow bandwidth of 1%. However, it is well known that the L-probe fed patch antenna [13] is a wideband antenna structure. Therefore, it is worthwhile to investigate the bandwidth performance of the novel water dielectric patch antenna.

Table I. Dimension and performance of antenna

	Design I	Design II	Design III
HA	10	20	30
LP	180	170	115
WP	80	80	80
LV	7.4	15.9	25.9
LH	57	44	33
S	35	35	33
HP	5	5	5
WG	350	350	350
Fo(Ghz)	0.95 Ghz	1.01 Ghz	0.98 Ghz
BW (S11<-10 db)	7.32 %	11.38 %	22.48 %
Max. Gain(dbi)	9.46 dbi	7.76 dbi	6.55 dbi

The bandwidth performance of antenna mainly depend on the height of the substrate, here the height HA for the three designs is 10, 20, 30 mm respectively. The centre frequency of the operating band is set at 1.02 GHz in this study. The permittivity and the loss tangent of the pure water are set as 81 and 0.04 . The performances of the designs are simulated with the assistance of a full-wave electromagnetic solver –CST STUDIO. The dimension and performance of antenna are shown in table 1. The impedance bandwidth significantly increases with the height of the air substrate. For Ha=10 mm the bandwidth is 7.32%, HA=20mm the bandwidth is 11.38% and for HA=30 mm the bandwidth is 22.48% with |S11| < -10 dB. From this result, it can be concluded that L-probe feeding is effective method to widen the bandwidth of antenna and gain of antenna is increase with thick substrate as compare to thin substrate. Therefore, it can be seen from the above

analysis that for any requirement of practical applications, a proper height of substrate may be selected to achieve the desirable bandwidth.

III. RESULT

The simulated $|S_{11}|$ and gain of WDDPA is as shown in fig. The simulated bandwidth is 7.32 % (0.85 Ghz to 1.2 Ghz), 11.38% and 22.48 % for antenna design of I, II and III respectively with $|S_{11}| < -10$ dB. The simulated gain is 9.46 dB, 7.76dB and 6.55 dB for antenna design of I, II and III respectively as shown in Table 1.

The S-parameter curve for design I as shown in fig. 5 showing the operating band of 0.85 Ghz to 1.2 Ghz with the centre frequency of 0.95 Ghz with the impedance bandwidth of 7.32 %.

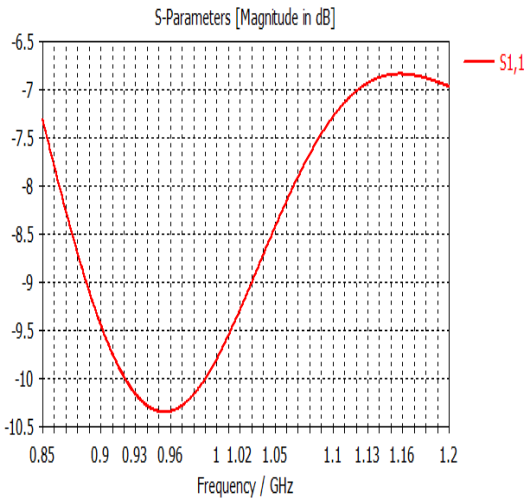

Fig. 5. Simulated $|S_{11}|$ parameter of proposed water dielectric patch antenna

The radiation pattern of design I as shown in fig. 6 showing the symmetrically unidirectional pattern with main lobe magnitude is 9.46 dBi at 1.025 Ghz.

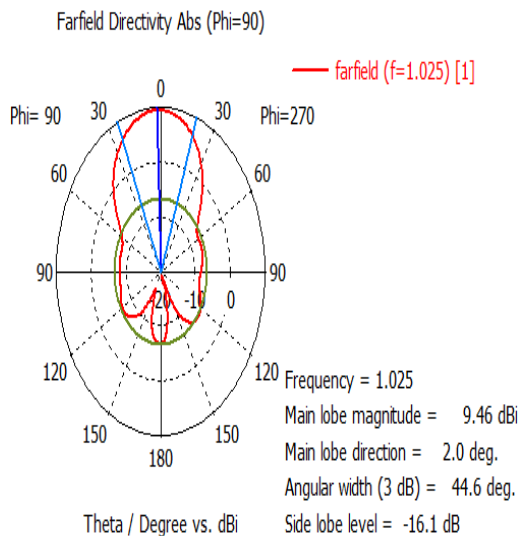

Fig. 6. Simulated radiation pattern of the proposed water dense dielectric patch antenna at the centre frequency of operating band.

The S-parameter curve for design II as shown in fig. 7 showing the operating band of 0.85 Ghz to 1.2 Ghz with the centre frequency of 1.01 Ghz and impedance bandwidth of 11.38 %.

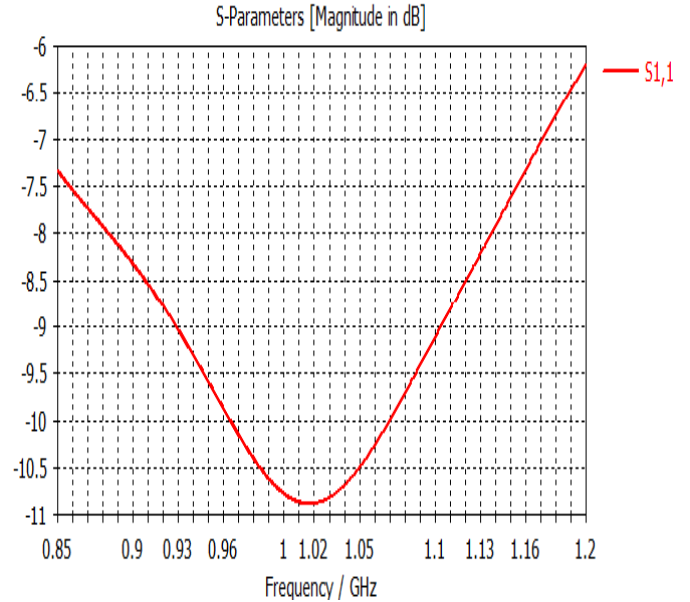

Fig. 7. Simulated $|S_{11}|$ parameter of proposed water dielectric patch antenna

The radiation pattern of design II as shown in fig showing the symmetrically unidirectional pattern with main lobe magnitude is 7.76 dBi at 1.025 Ghz.

Farfield Directivity Abs (Phi=90)

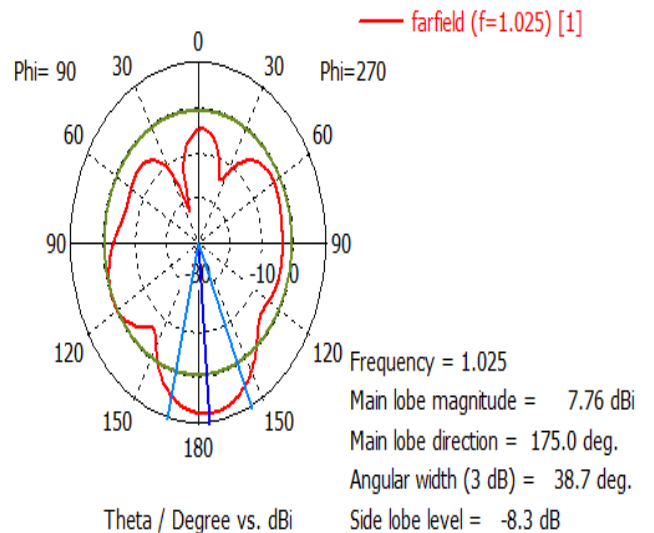

Fig. 8. Simulated radiation pattern of the proposed water dense dielectric patch antenna at centre frequency of the operating band.

The S-parameter curve for design III as shown in fig. 9 showing the operating band of 0.85 Ghz to 1.2 Ghz with the centre frequency of 0.98 Ghz and impedance bandwidth of 22.48 %.

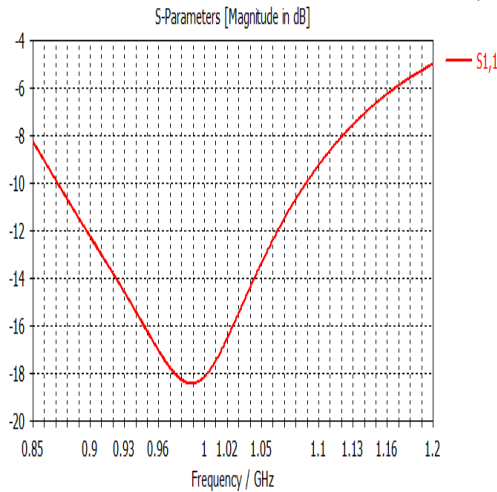

Fig. 9. Simulated |S11| parameter of proposed water dielectric patch antenna

The radiation pattern of design III as shown in fig showing the symmetrically unidirectional pattern with main lobe magnitude is 6.55 dBi at 1.025 Ghz.

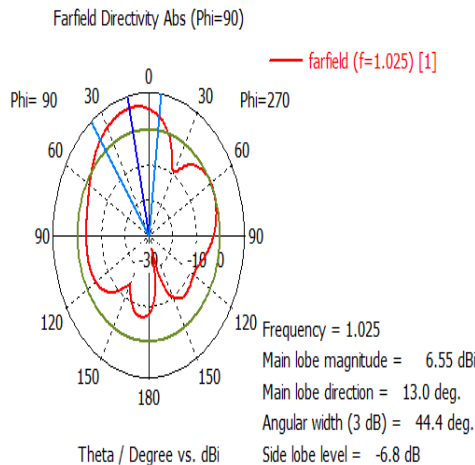

Fig. 10. Simulated radiation pattern of the proposed water dense dielectric patch antenna at the centre frequency of operating band.

Fig. 11 shows the 3D view far field directivity of water dense dielectric patch antenna

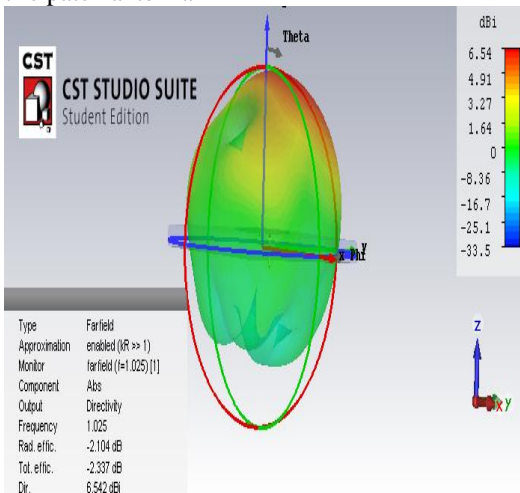

Fig. 11. Simulated 3D view far field directivity of water dense dielectric patch antenna

IV. FUTURE ENHANCEMENT

Antenna will be worked in dual band application.

V. CONCLUSION

An innovative water dense dielectric patch antenna fed by L-probe is proposed and investigated. The purposed water dielectric patch antennas constructed by using pure water same as a basic principle of conventional metallic patch antenna. The L-probe feeding is applied to the water patch antenna similar to L-probe feed metallic patch antenna. The bandwidth of the antenna is improved by increasing the thickness of supporting substrate between water patch and ground plane. The impedance bandwidth is 11.38 % with the maximum gain of 7.76dBi. The radiation pattern of the prototype is symmetrical with low back lobe and low cross polarization level.

REFERENCES

- [1] Y.Kosta and S.Kosta, "Liquid antenna systems," in Proc. IEEE AP-S Int. Symp., Jun. 2004, pp. 2392–2395.
- [2] Y. Kosta and S. Kosta, "Realization of a micro strip-aperture-coupled-passive-liquid patch antenna," in Proc. IEEE Int. RF Microw. Conf., Dec. 2008, pp. 135–138.
- [3] G.J.Hayes, J.-H. So, A. Qusba, M.D. Dickey, and G. Lazzi, "Flexible liquid metal alloy (EGaIn) micro strip patch antenna," IEEE Trans. Antennas Propag., vol. AP-60, no. 5, pp. 2151–2156, May 2012.
- [4] O.H.Karabey, S.Bildik, S.Bausch, S.Strunck, A.Gaebler and R.Jakoby, "continuously polarization agile antenna by using liquid crystal-based tunable variable delay lines," IEEE Trans. Antennas Propag., vol.61, no.1, pp. 70–76, Jan. 2013.
- [5] J.-C.S.Chieh and A.-V.Pharm, "A bidirectional micro strip X-band antenna array on liquid crystal polymer for beamforming applications," IEEE Trans. Antennas Propag., vol. 61, no. 6, pp. 3364–3368, Jun. 2013.
- [6] S. S. Alja' a freh, Y. Huang, and L. Xing, "A compact dual-feed water based diversity antenna," in Proc. Loughborough Antennas Propag. Conf., Nov. 2013, pp. 182–185.
- [7] L. Xing, Y. Huang, Y. Shen, S. Al Ja'afreh, Q. Xu, and R. Alrawashdeh, "Broadband U-shaped water antenna for DVB-H applications," in Proc. IEEE AP-S Int. Symp., Jul. 2014, pp. 1930–1931.
- [8] E. Paraschakis, H. Fayad and P. Record, "Ionic liquid antenna," in Proc. IEEE Int. Workshop Antenna Technol., Small Antennas Novel Metamater., Mar. 2005, pp. 552–554.
- [9] H. Fayad and P. Record, "Broadband liquid antenna," Electron. Lett., vol. 42, no. 3, pp. 133–134, Feb. 2006.
- [10] S.G.O'Keefe and S.P.Kingsley, "Tunability of liquid dielectric resonator antennas," IEEE Antennas Wireless Propag. Lett., vol. 6, pp. 533–536, 2007.
- [11] R.Zhou, H.Zhang, and H.Xin, "Liquid-based dielectric resonator antenna and its application for measuring liquid real permittivity's," IET Microw., Antennas Propag., vol. 8, no. 4, pp. 255–262, Mar. 2014.



ISSN: 2277-3754

ISO 9001:2008 Certified

International Journal of Engineering and Innovative Technology (IJET)

Volume 6, Issue 8, February 2017

- [12] H.W.Lai, K.-M.Luk, and K.W.Leung, “Dense dielectric patch antenna— A new kind of low-profile antenna element for wireless communications,” IEEE Trans. Antennas Propag., vol. 61, no. 8, pp. 4239–4245, Aug. 2013.
- [13] K. M. Luk, C. L. Mak, Y. L. Chow, and K. F. Lee, “Broadband microstrip patch antenna,” Electron. Lett. vol. 34, no. 15, pp. 1442–1443, 1998.
- [14] Yujian Li and Kwai-Man Luk, “A water dense dielectric patch antennas” IEEE access., Vol 3, pp. 274-280, March 2015.